

PORT WORKS DESIGN MANUAL

PART 2

Guide to Design of Piers and Dolphins

**Civil Engineering Office
Civil Engineering Department
The Government of the Hong Kong Special Administrative Region**

© The Government of the Hong Kong Special Administrative Region

First published, March 2004

Continuously updated e-version, June 2023

Prepared by :

Civil Engineering Office,
Civil Engineering Department,
101 Princess Margaret Road,
Homantin, Kowloon,
Hong Kong.

This Port Works Design Manual (PWDM) is a continuously updated version incorporating the PWDM Corrigenda issued since the PWDM was published. This continuously updated version is released in e-format only on the CEDD website. This PWDM is to be cited as “PWDM Part 2 (2023). Guide to Design of Piers and Dolphins (Continuously updated e-version June 2023). Civil Engineering Office, Civil Engineering and Development Department, HKSAR Government.”

FOREWORD
(Continuously updated e-version Jun 2023)

This continuously updated e-version of the Port Works Design Manual has incorporated the previously issued Corrigenda No. 1/2006 (June), No. 1/2014 and No. 1/2018 to facilitate the designers and industry practitioners to carry out coastal design in a more convenient manner.

Practitioners are encouraged to comment at any time to the Civil Engineering Office on the contents of this document, so that improvements can be made to future editions.



WONG Chi-pan, Ricky
Head, Civil Engineering Office
June 2023

FOREWORD

The Port Works Design Manual presents recommended standards and methodologies for the design of marine works in Hong Kong. It consists of five separate volumes, namely, Part 1 to Part 5. Part 1 mainly covers design considerations and requirements that are generally applicable to various types of marine works. Part 2 to Part 5 are concerned with specific design aspects of individual types of works including piers, dolphins, reclamation, seawalls, breakwaters and beaches. This Manual supersedes the Port Works Manual, of which the contents were prepared in the 80's.

This document, Port Works Design Manual : Part 2, gives general guidance and recommendations on the design of piers and dolphins. It was prepared by a working committee comprising staff of the Civil Engineering Office with reference to the latest international and local marine works design standards, manuals and research findings in consultation with Government departments and engineering practitioners. Many individuals and organizations made very useful comments, which have been taken into account in drafting the document. An independent review was also undertaken by experts in relevant fields before the document was finalized. All contributions are gratefully acknowledged.

Practitioners are encouraged to comment at any time to the Civil Engineering Office on the contents of this document, so that improvements can be made to future editions.



K C CHING
Head, Civil Engineering Office
February 2004

Working Committee of Port Works Design Manual : Part 2 [First published Version in 2004]

The preparation of the document was overseen by Chief Engineer/Technical Services :

Ir Tong Nai-piu

The document was drafted by the following staff of the Civil Engineering Office :

Ir Lee Wai-ping

Ir Dr Chu Chi-keung

Ir Lai Tsan-kei

Ir Wong Ching-piu

Assistance and advice were provided by the following staff of the Civil Engineering Office :

Ir Au Ying-kit

Ir Chiu Mau-fat

Ir Ko Wai-kuen

Ir Lam Chi-keung

Ir Li Yuen-wing

The document was reviewed by :

Professor Yoshimi Goda, Yokohama National University

Professor Lee Chack-fan, the University of Hong Kong

Professor Kwan Kwok-hung, the University of Hong Kong

CONTENTS

	Page No.
TITLE PAGE	1
FOREWORD	3
CONTENTS	5
1. INTRODUCTION	9
1.1 Purpose	9
1.2 Definitions and References	10
2. DESIGN CONSIDERATIONS OF PIERS	11
2.1 Definitions	11
2.2 Design Life	11
2.3 Vessel Characteristics	11
2.3.1 Design Data	11
2.3.2 Vessel Movements	12
2.4 Site Selection	14
2.4.1 Bathymetry and Approach Channel	14
2.4.2 Exposure to waves, winds and currents	14
2.4.3 Environmental Impact	15
2.4.4 Soil Conditions	15
2.4.5 Site Accessibility	15
2.5 Structural Forms	16
2.5.1 Open Structures	16
2.5.2 Solid Structures	16
2.5.3 Selection	17
2.6 Layout	17
2.6.1 Length and Width	17
2.6.2 Orientation	18
2.6.3 Deck Level	18
2.6.4 Depth Alongside	19
2.6.5 Transport Planning and Design	19
2.7 Fenders	19
2.7.1 Type of Fenders	19
2.7.2 Timber Fenders	20
2.7.3 Rubber Fenders	20

	Page No.	
2.7.4	Plastic Fenders	22
2.7.5	Arrangement of Fenders	22
2.8	Moorings	24
2.9	Other Pier Facilities	25
2.10	Aesthetics	26
3.	PILED DECK PIERS	27
3.1	General	27
3.2	Loading	28
3.2.1	Loading Conditions and Load Factors	28
3.2.2	Waves and Water Levels	28
3.2.3	Design Wave Height and Pressure	28
3.2.4	Lateral Loads	29
3.3	Fenders	30
3.4	Moorings	31
3.5	Structural Design	31
3.5.1	Pier Deck	31
3.5.2	Piles	32
3.6	Corrosion Protection for Pier Deck	34
3.6.1	Corrosion Mechanism	34
3.6.2	Protective Coatings	35
3.6.3	Cathodic Protection	37
3.6.4	Corrosion Monitoring	37
3.6.5	Corrosion Protection for Pier Facilities	38
3.7	Corrosion Protection for Piles	38
3.7.1	Steel Piles	38
3.7.2	Reinforced Concrete Piles	39
3.7.3	Corrosion Monitoring	39
3.8	Catwalk	39
3.9	Construction	40
3.9.1	General	40
3.9.2	Piling	40
3.9.3	Pier Deck	41
3.10	Maintenance	42
4.	SOLID PIERS	43
4.1	General	43
4.2	Stability	44
4.3	Loading	45

	Page No.
4.3.1 Loading Conditions	45
4.3.2 Water Levels and Waves	46
4.3.3 Design Wave Height and Pressure	46
4.3.4 Lateral Loads	47
4.4 Toe Protection	47
4.5 Fenders and Moorings	48
4.6 Corrosion Protection	48
4.7 Catwalk	48
4.8 Construction	49
4.8.1 General	49
4.8.2 Foundation	49
4.8.3 Rock, Armour and Underlayers	50
4.8.4 Concrete Blocks and Caissons	51
4.8.5 Pier Facilities	52
4.9 Maintenance	52
 5. DOLPHINS AND FLOATING PIERS	 53
5.1 Dolphins	53
5.1.1 Functions	53
5.1.2 Layout	53
5.1.3 Structural Design	54
5.1.4 Accessories	55
5.2 Floating Piers	55
5.2.1 Layout	55
5.2.2 Design Principles	56
5.2.3 Testing	57
 6. AESTHETICS	 59
6.1 Principles	59
6.2 Illustrations	59
6.3 Durability	60
 REFERENCES	 62
 TABLES	 65
List of Tables	67
Tables	69

	Page No.
FIGURES	77
List of Figures	79
Figures	81
PLATES	97
List of Plates	99
Plates	101
APPENDIX A DESIGN OF FENDERS	109
GLOSSARY OF TERMS	121

1. INTRODUCTION

1.1 Purpose

The purpose of the Port Works Design Manual (the Manual) is to offer guidance on the design of marine works and structures normally constructed by the Government of the Hong Kong Special Administrative Region. Such works and structures include public piers, ferry piers, dolphins, reclamations, seawalls, breakwaters, pumphouses, beaches and associated marine facilities. The Manual has been written with reference to the local conditions and experience. Therefore, it may also provide a source of useful data and design reference for other marine works and structures constructed by other organizations or parties in Hong Kong.

The Manual is issued in five separate parts. The titles of these parts are :

- Part 1 – General Design Considerations for Marine Works
- Part 2 – Guide to Design of Piers and Dolphins
- Part 3 – Guide to Design of Reclamation
- Part 4 – Guide to Design of Seawalls and Breakwaters
- Part 5 – Guide to Design of Beaches

The recommendations given in the Manual are for guidance only and should not be taken as mandatory. Compliance with these recommendations does not confer immunity from relevant statutory and legal requirements. Because of the variable nature of the marine environment, the design of marine works and structures relies particularly on the use of sound engineering judgement and experience. Practitioners should be aware of the limitations of the assumptions employed in a particular theoretical or computational method. Since the marine environment is a field where active research and development are continuing, it is beyond the scope of the Manual to cover all analysis and design methods. Practitioners should be prepared to explore other methods to suit a particular problem and should also realize that many of the methods will continue to evolve.

This part (Part 2) of the Manual gives guidance and recommendations on the design of piers and dolphins. In using this part of the Manual, readers should refer to other parts of the Manual on particular aspects, as necessary.

1.2 **Definitions and References**

The definitions of terms for the purpose of this part of the Manual are given in the Glossary of Terms at the end of this document.

The titles of the publications referred to in this part of the Manual are listed in the reference section. Readers should consult these original publications for more detailed coverage of particular aspects. For Works Bureau Technical Circulars (WBTC) or Environmental, Transport and Works Bureau Technical Circular (Works) (ETWB TCW) which are updated regularly, reference should be made to their latest issues.

2. DESIGN CONSIDERATIONS OF PIERS

2.1 Definitions

BS 6349: Part 2 (BSI, 2010) defines piers as follows :

- ⌘ Pier – A structure projecting from the shore at which berths are provided.
- ⌘ Jetty – A structure providing a berth or berths at some distance from the shore. A jetty may be connected to the shore by a catwalk.
- ⌘ Wharf – A berthing structure backing on to the shore or reclaimed land. It is also called a quay.

Piers with berths on both sides and wharves with berth(s) for alongside berthing may be constructed as shown in Figure 1, depending on the requirements of the pier facilities. If the water depth near the shore is too shallow to accommodate the vessels, a jetty connected to the shore by a catwalk may be constructed over deeper water. Typical jetty layouts are shown in Figure 1.

For the purpose of this part of the Manual, jetties and wharves will broadly be called piers to simplify explanations, unless otherwise specified.

2.2 Design Life

The design life for all permanent piers should be taken to be 50 years, unless there are special circumstances. General guidance on the determination of the design life in special circumstances and its relationship with the return period of an extreme event is given in Chapter 3 of Part 1 of the Manual.

2.3 Vessel Characteristics

2.3.1 Design Data

General characteristics of local vessels are given in Tables 36 and 37 Chapter 3 of Part 1 of the Manual. However, the latest information on these vessels and other types of vessels not

shown in the Manual should be obtained from clients, vessel companies and pier operators. All vessel data adopted in the design should be agreed with relevant parties, after due consideration of the use of the pier.

The characteristics of the vessels that influence the design of a pier include the length, beam, draft, displacement, shape and size of hull and superstructure of vessel, passenger carrying capacity, cargo type and cargo handling capacity.

<i>Vessel Characteristics</i>	<i>Design</i>
<ul style="list-style-type: none"> • Length 	- Length and layout of the pier.
<ul style="list-style-type: none"> • Beam 	- Width of the berthing basin and approach channel, reach of cargo-handling equipment.
<ul style="list-style-type: none"> • Draft 	- Water depth along the berth and approach channel.
<ul style="list-style-type: none"> • Displacement 	- Berthing energy and fendering system.
<ul style="list-style-type: none"> • Size and shape of hull and configuration of vessel superstructure 	- Fendering and mooring systems, positioning of configuration of vessel pier superstructure and facilities.
<ul style="list-style-type: none"> • Passenger carrying capacity 	- Waiting area, access ramp and passenger facilities.
<ul style="list-style-type: none"> • Cargo type and handling capacity 	- Storage requirement and cargo handling equipment.

The positioning and design of the pier facilities such as passenger access ramp or cargo handling equipment must cater for the position of the superstructure of all vessels which may use the facilities, during all states of tide. Care should be taken to eliminate the possibility of collisions between such facilities and the superstructure of the vessels.

2.3.2 Vessel Movements

There are six degrees of freedom of movement of a vessel (see Figure 2). The three translational components are surging along the longitudinal axis, swaying along the lateral axis and heaving along the vertical axis. The three rotational components are rolling about the longitudinal axis, pitching about the lateral axis and yawing about the vertical axis. Ship movements induced by waves, winds and current influence the design of the pier such as its fenders, moorings and water depth.

When a vessel is moored at a pier, the movements in the horizontal plane, including surge, sway and yaw, are subject to the restraining forces of the mooring lines and the fenders which tend to counteract the movement of the vessel from its equilibrium position. The oscillation of the vessel in these three directions is governed by the mass of the vessel, the added mass of the surrounding water affected by the oscillation, the configuration and stiffness of the mooring lines and the fenders. These movements are usually not critical for small to medium-size vessels that are normally under sufficient restraint. However, for large vessels under long period waves, the mooring forces can be very high and may exceed the breaking limit of the mooring lines.

The movements of the vessel in the vertical plane, including roll, pitch and heave, are almost unaffected by the fenders and the mooring system. Since these movements are influenced by the gravity as a restoring force, they exhibit natural periods of free oscillation. The added mass effect can significantly affect the natural period in heaving and pitching but much less for rolling. When the natural periods are close to periods of the incident waves, these movements will be greatly amplified, and will affect the efficiency and safety of the operations on the pier and vessel. Such situations should be avoided in the design; if unavoidable, the heights of the waves reaching the pier and vessels should be attenuated as much as possible by provision of breakwaters and/or other protective facilities.

The analysis of the movements of the vessel cannot be handled by simple analytical method. There are some general guidelines, however, that may be sufficient in simple cases, such as piers for small to medium-size vessels or piers in relatively sheltered locations, as explained later in this chapter. For complicated situations, use of sophisticated computer-programmed mathematical models and/or undertaking hydraulic model tests may be necessary to simulate the vessel movements to determine the mooring forces and the arrangement of the fendering and mooring systems. Nowadays, the technique of simulating vessel movements by computer modelling has well been developed. These computer models use the input of the time histories of random waves, fluctuating wind forces and currents, and then compute the movements of vessels stepwise in time sequence. The output is statistically analyzed to yield the distributions of the amplitude of vessel movements and mooring forces. Hydraulic model tests are not so often performed recently at many advanced laboratories in the world because of the difficulty in properly manufacturing models of mooring lines. In any case, specialist's advice or input should be sought as appropriate.

2.4 Site Selection

2.4.1 Bathymetry and Approach Channel

Adequate water depth must be available around the proposed pier location for the navigation, berthing and mooring of the vessels. If the water depth near the shore is not sufficient, the pier may be constructed further offshore at deeper water and connected to the shore by a catwalk but the pier may be exposed to more severe wave conditions. Alternatively, if the pier is to be constructed in shallow water, an approach channel may be dredged to allow the vessels to access the pier.

General guidance on the design of approach channel is given in Chapter 3 of Part 1 of the Manual. To ensure safe navigation, a minimum under-keel clearance of 10% of the vessel's deepest draft is required at all tidal levels in the manoeuvring basins, sheltered fairways and approaches to berths, and 15% for exposed waterways. Suitable allowances for squat, trim and wave-induced motion should also be provided, and additional clearance may be required where the seabed is rocky. The Marine Department should be consulted about the dimensions of the approach channel.

The amount and the rate of siltation in the channel should be estimated to determine the frequency of maintenance dredging in the future. An estimate of siltation can be made by referring to records of sounding survey and maintenance dredging, and information about sediment discharged from adjacent rivers, as well as by means of mathematical modelling methods.

2.4.2 Exposure to Waves, Winds and Currents

Where possible, the pier should not be located in an area exposed to strong winds, waves and currents that will make vessel berthing and mooring very difficult or unsafe. The configurations and the features of the shore should be studied to select a suitably sheltered location. The types of vessels travelling near the pier, their speeds and frequencies of travel should be investigated to determine the effect of vessel generated waves on berthing and mooring, because waves from moving vessels, in particular high speed ones, will cause confused seas. General characteristics of waves generated by various types of vessels operating in Hong Kong waters are summarized in Table 1. Where possible, the pier for small and/or medium size vessels should not be located too close to a busy navigation fairway. Large vessels are not affected by vessel generated waves of which the periods are normally in the range of several seconds or less. **Variation in loads throughout structure design life as result of climate change (including variations in hydrostatic load and, normal wind and wave environmental loads) may be expected over the design life of the structure and structural performance should be checked at the beginning and end of the design life of the structures.**

2.4.3 Environmental Impact

It is important to determine whether the structure will affect the hydrodynamic regime, water quality and ecology. Effects on the hydrodynamic regime may include changes in currents, wave climate and sediment transport pattern which may result in impacts on water quality and ecology. Dredging or piling works during construction may also have an impact on the environment, and efficient measures should be employed to prevent dispersion of suspended sediment.

Depending on the location and size of the pier, an environmental impact assessment may be necessary to determine the type and extent of the impacts as well as associated mitigation measures. Guidelines on environmental impact assessment are given in the Technical Memorandum on Environmental Impact Assessment Process (EPD, 1997). The effects of small piers on the environment may be localized. Mathematical modelling can assist in studying the hydrodynamic regime and water quality in the environmental impact assessment.

2.4.4 Soil Conditions

Ground conditions should be investigated before selecting the pier location as they can affect the foundation design such as the depth of piling or dredging works. Reference should be made to [Geoguide 2 \(GEO, 2017a\)](#) for guidance on good site investigation practice, [Geoguide 3 \(GEO, 2017b\)](#) for guidance on description of rocks and soils in Hong Kong, and [Geospec 3 \(GEO, 2017c\)](#) for a model specification for soil testing. Specific details of site investigation and soil testing for marine works are given in Chapter 4 of Part 1 of the Manual. Guidelines for site investigation in difficult marine ground conditions, such as those with thick marine deposit or extensive interbedded soft alluvium, are given in the report “Study on Coastal Subsoil Geotechnical Conditions” (CED, 2003a).

2.4.5 Site Accessibility

For ferry piers, the following issues should be considered in consultation with Transport Department. These include the attractiveness and accessibility of the site, phasing and programme of the developments in the vicinity of the piers, road networks and availability of feeder services and covered walkways. Marine Department and Transport Department should be consulted on aspects such as the possible effects of the piers on adjacent marine activities and the routing of ferry services.

2.5 Structural Forms

2.5.1 Open structures

Open structures usually comprise a deck supported on piles. A typical piled deck pier is shown in Plate 1.

Depending on the arrangements of the piles, piled deck piers can be designed as either flexible or rigid structures. A flexible structure is one with vertical piles only. Structural weight, vertical live loads and horizontal imposed loads are carried by the deck and distributed to the piles. These loads are transmitted to the soil through the bending of the piles and compressive resistance of the soil. Depending on the member stiffness, capacity and fixity of the piles in the soil, this arrangement may be possible if the lateral deflections of the pier are not excessive. Otherwise, a rigid structure with raking piles can be adopted to transmit horizontal loads through pile compression to the soil. In both cases, the deck distributes the horizontal loads to the piles.

A reinforced concrete deck supported by either concrete piles or steel tubular piles is common. The deck is usually composed of precast concrete beam and slab units to minimize formwork over water. The advantages of piled deck piers are that they do not cause wave reflection and water circulation problems of solid structures. In addition, dredging of soft marine or alluvial deposits is not required because the loads are transmitted down to the supporting soil stratum by the piles. However, the structural arrangement of a piled deck pier is more complicated. More detailing effort is required in the design stage to determine the structural layout. As piling works are involved, piled deck structures are usually more expensive than solid structures. Furthermore, greater maintenance is necessary for the reinforced concrete deck and concrete piles due to chloride induced corrosion of the reinforcement, and the corrosion protection for steel piles.

2.5.2 Solid structures

Solid structures include precast concrete blockwork or caisson structures with solid vertical berthing face. A typical solid pier made of precast concrete blocks is shown in Plate 2.

Solid piers made up of precast concrete blocks are very common in local condition because of the low construction and maintenance cost. However, there are several disadvantages with the use of solid piers. Firstly, in areas with strong waves, incident waves and waves reflected from the solid piers may combine to form standing waves in front of the piers.

This will make berthing difficult for small and medium size vessels (Large vessels are not affected by vessel generated waves with periods of several seconds or less). Secondly, solid structures do not allow passage of currents. If there are strong currents at the pier location, local eddies induced by the solid structures will introduce additional berthing difficulties. Furthermore, dredging works are usually required for the construction of the foundation of solid piers due to the presence of soft marine mud underneath the seabed in most of the coastal area of the Territory. The suspended sediment generated during dredging may have a detrimental effect on the water quality of nearby waters. Therefore, measures such as introducing openings in the piers and enclosing the dredging area with a silt curtain should be considered to avoid undesirable impacts.

The reflected waves from solid piers will cause wave agitation and affect navigation and operation of nearby vessels. New marine structures in Victoria Harbour should be designed to achieve a reflection coefficient less than 0.5 for waves with periods less than 5s to reduce the impact of reflected waves on vessels. Hence, the use of solid piers may not be appropriate within the Harbour.

2.5.3 Selection

A summary of the advantages and disadvantages of solid piers and piled deck piers is given in Table 2. Generally, it is necessary to evaluate the relative merits of these forms with respect to the site conditions, cost of construction, future maintenance, extent of the environmental impact and associated mitigation measures, effects on operations and other project constraints before a decision can be made. The expectations of the local community should also be considered, where appropriate.

2.6 Layout

2.6.1 Length and Width

The length of the pier depends on the number and length of vessels using the pier at the same time, and the operational requirements of those vessels. The width of the pier depends on the usage of the pier, passenger flow and waiting area, method of cargo handling and available backup area. Such information should be checked with the client and the operator of the pier as well as government departments concerned. The length of the pier may be limited by the need to maintain sufficient clearance from adjacent fairways, anchorage areas or harbour operations. The advice of the Marine Department should be sought.

Where a mix of different types of vessels can use the pier, it may not be necessary to design the length of the pier for the longest vessel. A study of the usage frequency of various vessels, berthing methods, operations on the pier and safety should be carried out to optimize the length. If several vessels are allowed to berth in a line at the time, the distance allowed between vessels berthed in line will depend on the method of berthing, and should be determined with the Marine Department and the pier operators. For fishing and pleasure vessels, a berth length of 1.15 times the vessel length is desirable (BSI, 2010). The length of the pier is also affected by the mooring layout (BSI, 2014).

The determination of the length and width should also take account of changes in the demand of usage and the size of vessels expected during the design life of the pier. For piers owned by the government, under the Shipping and Port Control Regulations (Chapter 313A), no vessel exceeding 35 m in length should go alongside the pier except with the permission of the Marine Department.

2.6.2 Orientation

The effect of wave period and direction on the berthing and mooring operations should be investigated to ensure the safety of all pier and vessel operations such as cargo handling and passengers boarding and alighting. This can be carried out by simulating the vessel's movements due to wave action using computer-programmed mathematical models and/or hydraulic model tests. However, there are some general rules that may be sufficient in simple cases. As a general guidance, the pier should not be exposed to broadside wave action, as this will increase undesirable vessel movements as well as mooring and fender forces. Where practical, the pier should be aligned with the direction of the most significant wave direction or the berths on the pier may be located in such a way to avoid broadside wave action. Such considerations also apply to winds and currents.

In Hong Kong, the northeasterly monsoon is usually stronger than the southwesterly monsoon. Therefore, waves due to northeasterly monsoon are generally higher than those generated by the southwesterly monsoon. Where practical, the pier should not be exposed to the effect of northeasterly monsoon.

2.6.3 Deck Level

The deck level depends on the level of adjacent land, tidal variation, extreme water levels, type of vessels and pier operations, and the headroom required for carrying out maintenance

below the pier deck in the case of piled deck structures. A typical level for the main deck of piers for ferries, pleasure crafts and similar types of vessels in the Territory is about +4.0 mPD to +5.0 mPD. Relevant government departments, vessel or pier operators and the maintenance authority should be consulted. Wave overtopping at deck level should be checked to ensure that overtopping rates are acceptable for the intended usage of the pier.

2.6.4 Depth Alongside

The depth of water alongside the berth is determined by the draft of the vessels using the pier, the tidal range and the effects of wave action. An under-keel clearance in calm conditions should generally be at least 10% for the deepest draft vessel alongside the pier under all tidal conditions, but suitable allowances for trim and wave-induced motion should also be provided. Squat refers to the sinking of the stern of a vessel while sailing at a certain speed, and therefore it is not applicable to vessels at berths. Additional clearance may be required where the seabed is rocky.

General information on the draft of vessels is given in Tables 36 and 37 of Part 1 of the Manual. However, all vessel data should be checked with the Marine Department, relevant government departments and the vessel or pier operators as appropriate before adopted for design purposes.

2.6.5 Transport Planning and Design

Chapter 7 of Volume 9 of the Transport Planning and Design Manual (TD, 2003) provides design guidance such as layout, siting, vessel draft allowance, passenger waiting areas and linkspan arrangement for ferry piers. The designer should take into account relevant requirements in the design of ferry piers.

2.7 Fenders

2.7.1 Type of Fenders

The purpose of installing fenders on the pier is to protect the vessel and the pier from damage when the vessel berths alongside the pier. The fenders absorb the berthing energy of the vessel and soften the berthing impact on the pier. Fenders can be classified into timber fenders, rubber fenders and plastic fenders, according to the type of materials used. A comparison of their performance is summarized in Table 3.

2.7.2 Timber Fenders

Timber fenders are mainly produced from tropical hardwoods and such application is not environmentally friendly. There is also a high damage rate for the timber fenders due to wear and tear by vessels and this has resulted in substantial maintenance requirement. Hence, further use of timber fenders is not recommended.

2.7.3 Rubber Fenders

Rubber fenders are produced from natural or synthetic rubber. Rubber fenders are available in a wide range of forms and dimensions designed to meet the requirements of a variety of operating conditions. They are designed to absorb the berthing energy by means of their deflection. Advice should always be sought from one or more of the major reputable suppliers regarding the energy absorption characteristics, fender reaction, deflection and other installation details. [Section 21 of General Specification for Civil Engineering Works \(GS\) \(HKSARG, 2020\)](#) stipulates the testing standards and requirements for rubber fenders.

Rubber fenders can be classified into two categories based on their performance. Buckling or constant reaction type fenders have a reaction load that increases more or less linearly in the initial stage of deflection as a result of elastic compressive deformation. However, when the reaction load reaches a certain magnitude, it tends to remain almost constant regardless of the increase in deflection due to elastic buckling, until the hollow portion of the fender is closed. After closure of the hollow portion of the fender, elastic compressive deformation is restored, resulting in further increase in the reaction load.

Another category is the constant elastic modulus type fenders for which the reaction load will increase approximately in proportion to the increase in deflection. As soon as the hollow portion of the fender is closed, the behaviour of the fender is similar to the buckling type fender. Different types of rubber fenders and their general performance are shown in Figure 3.

(1) Cell Fenders

Cell fenders and other large unit fenders are usually mounted individually in a series (see Plate 3). Each of the fenders is designed to absorb the berthing vessel's energy on its own. Steel frontal frames may be installed for load spreading to keep contact pressures within acceptable limits. In some fender systems, these unit fenders are connected together to

provide a larger energy absorption capacity or to cover a larger operational range of vessels.

(2) Pneumatic and Foam-filled Fenders

Pneumatic and foam-filled fenders are characterized by their high energy absorption and low reaction force (see Plate 4). Pneumatic fenders comprise a hollow rubber bag filled with air whereas foam-filled fenders comprise a resilient closed cell block covered by a reinforced rubber skin. These fenders are designed to absorb berthing energy by the work required to compress the air or foam cells. They are generally in the form of cylinders with domed ends floating in front of the berth structure. Chains or wire ropes with swivels and shackle connections are used to anchor the fenders to the berth structure.

(3) Long Strip Rubber Fenders

Long strip rubber fenders are more suitable for installation on piers designed for use by smaller vessels. They are generally more economical than the larger cell fenders and pneumatic or foam-filled fenders. Common forms of long strip fenders include cylindrical, D, arch and turtle fenders. A comparison of the general features of these fenders is given in Table 5.

Cylindrical fenders are usually supported on chains but can also be fixed in position as shown in Plate 5. The energy absorption capacity is among the lowest of the long strip fenders for a given section height.

D fenders differ from cylindrical fenders by having a flat surface to facilitate installation and therefore they can be directly fixed on the vertical surfaces of the piers. The curved contact surface provides a soft initial contact between the vessel and the berth structure. The area of contact increases with the energy absorbed during the berthing operation.

Installation of arch fenders is relatively simple. The fenders can be fixed directly on the vertical surfaces of the piers (see Plate 4). The energy absorption capacity provided is relatively high compared to other long strip fenders since the energy is absorbed mainly through compression deformation rather than deflection. The reaction force is also large, resulting in a relatively high contact pressure.

The turtle fender is a relatively new type of rubber fender designed for small craft port facilities, and is characterized by a wide protective area and a relatively large energy absorption capacity for a given section height. It possesses a large breadth to height ratio to

minimize damage in severe mooring conditions. The large area of contact results in lower contact pressure for a given reaction force. Similar to the arch fender, each turtle fender can be fixed directly on the pier with two rows of fixing bolts.

2.7.4 Plastic Fenders

Plastic fenders are produced from recycled plastic, which consists of a mixture of high density polyethylene, low density polyethylene and polypropylene (see Figure 4). Antioxidants and ultraviolet inhibitors are added to retard the effects of ultraviolet light on the plastic. Fibre glass or steel reinforcing bars are normally provided to enhance the flexural and tensile resistance. The reinforcing bars are arranged in a regular pattern within the core of the fender and extend over the entire length of the fender. The type, size and number of reinforcing bars depend on the structural requirements of the application.

Current products of plastic fenders are produced to American Society of Testing and Materials Standards (ASTM) for plastics. A list of the standards for testing the physical properties of plastic fenders, including density, water absorption, impact resistance, hardness, resistance to ultraviolet, abrasion, coefficient of friction and strength of fibreglass reinforcement, is shown in Table 6.

Plastic fenders can sustain and transfer the berthing load to the pier. However, these fenders possess less energy absorption capacity and hence result in higher berthing load to the piers compared to rubber fenders. Hence, rubber fenders are normally combined with plastic fenders to improve the energy absorption capacity and berthing comfort (see Figure 4). In such an arrangement, the plastic fender acts as a beam to transfer the berthing energy and berthing load by bending to the supporting rubber buffer. Information on the flexural strength, moment of inertia and modulus of elasticity of plastic fenders is required in the design, and advice should be sought from one or more of the major reputable suppliers for detailed design information. Plastic fenders have been used locally as a replacement for timber fenders on existing piled deck piers (see Plate 6).

2.7.5 Arrangement of Fenders

Reference should be made to the manufacturers' catalogues when designing the layout of the fenders, as the dimensions, deformation and fixing details of a selected type of fender will affect how the fenders are arranged to perform effectively during vessel berthing. In particular, the following points should be noted :

- The design of the vertical position of the fenders should take into account the range of freeboard of the vessels so that all vessels using the pier can be in contact with the fenders during berthing under all possible tidal levels (see Figure 5a) throughout the structure's design life including the possible effects of climate change.
- The horizontal interval of the fenders should be determined to avoid the vessel from making direct contact with the pier under the designed berthing angle and deflection of the fenders, due to the horizontal curvature of the vessel's hull (see Figure 5b).
- The vessel may contact the pier directly due to its vertical curvature. For example, if the fenders are installed at a low level, the upper part of the vessel may strike the pier before the fender is compressed to the designed deflection (see Figure 5c).
- Many small vessels have projections like belting to protect the hull. When the projections contact a fender directly, the fender may be compressed locally and damage such as cracking and cutting may occur. A steel frame may be installed on the face of the fender to avoid such damage (see Figure 5d).
- The distance between the edge of the pier and the side of the hull when the vessel is moored should be checked (see Figure 5e).
- The pressure on the vessel's hull when berthing energy under the worst conceivable approach conditions should not exceed the acceptable contact pressure on the vessel's hull.

For public piers designed for pleasure yachts, trading vessels, motor launches, fishing vessels, kaitos and sampans, from past experience fenders extending from about +0.15 mPD to +4.15 mPD are considered appropriate in order to cater for a wide range of vessel sizes over a 50 year design life. However, if public piers are to accommodate larger ferries, barges or tug boats, fenders should be to a specific design.

Fenders should in principle be installed on the portion of the pier where berthing will take place. However, it may sometimes be necessary to install fenders at the remaining pier portion to allow for accidental berthing, berthing under emergency circumstances or increase in future demand. A comparison of the benefits gained should be made against the increased cost of installing additional fenders.

2.8 Moorings

Moorings are provided to prevent vessels from drifting away from a berth or from colliding with adjacent moored vessels. Movement should be restrained by means of an adequate number of mooring lines, which can be readily handled by the operating personnel, compatible with the conditions of winds, tides, waves and other effects likely to be experienced during the period a vessel is berthed. The mooring layout is dependent on the size and type of vessel using the berth, and the position, spacing and strength of the moorings on the pier. The following points should be noted when designing the mooring system (see Figure 6) :

- The mooring system should be symmetrical to ensure even distribution of the restraining forces on the vessel.
- The mooring lines should not be too short to avoid steep angles of the lines, which will result in poor load distribution. The mooring lines should not be too long to avoid excessive movement of the vessel.
- The spring lines should be aligned as close to the longitudinal direction of the vessel as possible to provide the maximum restraint against the vessel surging along the pier.
- The breast lines should be roughly aligned perpendicular to the longitudinal direction of the vessel to provide the maximum restraint against the vessel from being moved broadside from the pier.
- Head and stern lines are generally not necessary provided that mooring points are suitably designed and arranged. Head and stern lines may however be required to provide assistance in ship manoeuvring in some situations, for example, where a vessel is being moved along a pier without use of main engine or where there is exceptional asymmetrical current or wind loads.
- The vertical mooring angle should be as small as practicable and preferably not greater than 25°.
- The mooring system should be able to cater for various sizes and types of vessels using the pier.

Moorings loads from vessels' lines are applied through pier fittings such as bollards fixed to the top of the deck. A bollard (see Figure 6) is usually in the form of a short metal column fixed on the surface of the pier deck for the purpose of securing and belaying wire ropes or hawsers to restrain movement of the vessels at the pier. Bollards made of cast iron collar infilled with reinforced concrete are commonly used at the pier.

Where small vessels will use the pier, mooring eyes (see Figure 6) made of solid bars may be provided to give a mooring facility accessible directly by these vessels at all tidal levels. The mooring eyes should be recessed into the berthing face to prevent them damaging vessels.

In determining the layout and capacity of the mooring bollards, it is necessary to obtain technical comments from the Marine Department, the vessel and/or pier operators as appropriate. For government public piers which accommodate vessels less than 35 m in length, typical 10 tonne bollards are considered appropriate from past experience, with a reasonable number of mooring eyes at each berth for use by smaller vessels. However, if the piers are to accommodate larger vessels, larger bollards should be used.

2.9 Other Pier Facilities

The types and details of facilities to be installed are dependent primarily on the functions of the pier, and should be determined in consultation with the Marine Department, clients, pier and vessel operators, as well as relevant government departments. Examples of facilities that are normally installed for various types of piers include :

- Ferry piers
 - Passenger access ramp, waiting area, seats, handrails, shelter, turnstiles, toilets, staff rooms, stairways, lighting, trench for power supply and ducting, navigation aids, signs, etc.
- Public piers for pleasure crafts, kaitos, motor launches and similar types of vessels
 - Waiting area, landing steps, handrails, shelter, seats, lighting, trench for power supply and ducting, navigation aids, marine notice board, signs, etc.
- Cargo handling piers
 - Cargo handling cranes, mechanical handling equipment, crane tracks, backup and storage areas, paving for vehicles, lighting, trench for power supply and ducting, navigation aids, signs, etc.

The layout of the pier and its structural elements should be designed to allow construction or fitting of the facilities or equipment on the structure. Input from mechanical engineers and electrical engineers is required for the design of power supply, lighting, electrical and mechanical equipment such as movable passenger access ramp, as appropriate.

For ferry piers and public piers, strong wave induced motions of vessels will affect the safety

of passengers embarking and disembarking. Passengers may find it difficult to walk on the gangplank or may even lose their balance when small vessels moor at a pier in rough sea conditions. Marine Department should be consulted at an early stage as to whether any provision to permit a better gangplank or transfer system for the passengers can be incorporated in the design. Lifesaving equipment should be provided at suitable locations on the piers.

2.10 Aesthetics

A pier may become a prominent feature on the seafront and its appearance may have a visual impact on the surrounding landscape. Therefore, apart from meeting the functional and safety requirements, the design of a pier should take into consideration the aesthetic aspects to ensure that its appearance is in harmony with the environment. Some general guidelines have been given in Chapter 8 of Part 1 of the Manual. Specific aspects are further elaborated in Chapter 6 of this part of the Manual.

3. PILED DECK PIERS

3.1 General

There are two major structural forms for piled deck piers, namely, flexible structures and rigid structures, as shown in Figure 7.

For flexible structures supported by vertical piles only, relatively large lateral deflection will occur when they are subjected to horizontal forces. Flexible structures are less capable of resisting berthing forces and therefore they may not be suitable for accommodating large vessels. Rigid structures usually consist of pairs of piles raking in opposite direction to form a truss to resist the horizontal forces. They are strong in resisting berthing forces and therefore they can accommodate larger vessels than flexible structures.

The following steps are normally involved in the design of a piled deck pier :

- Determine the design conditions, such as the design life, return period of loads, type and dimensions of vessels, and operations and installations on the pier.
- Determine the layout of the pier, such as the shape and dimensions of the deck, deck level, orientation, arrangement of fenders and moorings, locations of facilities and installations, dimensions of pier superstructure.
- Determine the depth alongside the pier and if an access channel is required.
Design the fenders for the pier.
- Calculate the self-weight of the pier and the external forces, such as surcharge,
- live loads from pier operations, berthing and mooring loads, environmental loads including wind, wave and current loads, buoyancy and wave uplift.
- Examine the stability of slopes, if any, under the pier deck.
- Determine the layout of the piles and structural arrangement of the deck.
Carry out structural analysis to determine the stresses in piles and structural
- members.
- Determine the founding depth and calculate the size and bearing capacity of the
- piles.
- Calculate the size and amount of reinforcement of structural members.
- Design the facilities to be installed on the pier.
- Design corrosion protection for piles, structural members and pier facilities.
Refine detailed design of the pier.

This design sequence is subject to adjustment to suit the output of individual steps. Aspects of the design conditions and layout of the pier have been mentioned in Chapter 2 of this part of the Manual. Specific aspects of the determination of loading, structural design of piles and reinforced concrete, corrosion protection and construction for piled deck piers are given in this chapter.

3.2 Loading

3.2.1 Loading Conditions

Guidance on the loading conditions, including normal loading conditions, extreme loading conditions, temporary loading conditions and accidental loading conditions, and the methods of assessment of the nominal loads acting on a pier is given in Chapter 5 of Part 1 of the Manual. Other loading conditions that may be critical in the design life should also be investigated. Various loads should be combined in a way that is consistent with the probability of simultaneous occurrence. [Reference should also be made to Section 5 of BS 6349: Part 2 \(BSI, 2010\).](#)

3.2.2 Waves and Water Levels

The wave conditions and water levels normally considered in the design are given in Section 5.10.2 of Part 1 of the Manual. Depending on the wave height and the water level, the pier will be subject to wave uplift if the wave crest hits the soffit of the pier deck, in addition to the buoyancy force on the submerged portions of the pier.

3.2.3 Design Wave Height and Pressure

A piled deck pier may be considered as comprising a solid concrete deck edge and piles for the purpose of calculating the wave forces on the structure, as recommended in Section 5.10.5 of Part 1 of the Manual.

There is no clearly recommendable formula available for calculating the lateral wave force on the deck edge. In this connection, the lateral wave force may be determined by the method of Goda (BSI, 2000), given in Section 5.10.3 of Part 1 of the Manual. The effective depth of the deck depends on the layout of the deck, such as the depth of the beams and slabs, and must be assessed by the designer. As this method assumes no wave passing behind the structure but normal piled deck piers allow some wave passing, the method of Goda tends to overestimate the wave pressure exerted on the deck edge. The design wave height is the

maximum wave height H_{max} . For design purpose, H_{max} may be taken as $1.8H_{1/3}$, where $H_{1/3}$ is the significant wave height.

The wave uplift on the deck may be estimated with reference to the average uplift pressure measured in the study on wave absorbing seawalls (HKU, 1998), which is in the order of 1.3 to $1.7\gamma_w H_{max}$, where γ_w is the unit weight of seawater (see Section 5.10.6 of Part 1 of the Manual). However, it should be noted that the instantaneous uplift pressure may locally rise more than $10\gamma_w H_{max}$, but the equivalent static pressure for calculating stresses within the deck should be less than 4 times the hydrostatic head of the design wave height (OCDI, 2002).

The wave force on the piles may be assessed separately by Morison's equation (see Section 5.10.4 of Part 1 of the Manual). The design wave height is the maximum wave height H_{max} , and may be taken as $2H_{1/3}$ seaward of the surf zone, or if the structure is in the surf zone, the highest of the random breaking waves H_{max} at a distance equal to $5H_{1/3}$ seaward of the structure given by the equations in Appendix A of Part 1 of the Manual. A marine growth of 100 mm may be assumed on the piles below the mean sea level for the purpose of calculating the wave force if no other information or measurement is available. For piles closer than about four pile diameters, the loading on the front piles standing side by side in rows parallel to the wave crest should be increased by the factors in Section 5.10.4 of Part 1 of the Manual.

The maximum wave forces on the deck edge and the front piles may occur simultaneously but the maximum wave forces may not occur simultaneously at all piles in a pile bent.

3.2.4 Lateral Loads

Critical loading combinations due to major lateral loads acting on a pier/jetty and a wharf may be different. The critical case for a piled deck pier or jetty may include loads due to a wave crest and berthing acting on one side of the structure, and mooring on the other side, depending on the wave direction, berthing and mooring arrangement. Lateral wave suction is normally not considered as long as the level of the wave trough is lower than that of the deck soffit. For a one-berth wharf, berthing force and mooring force may not occur simultaneously as berthing is only allowed on one location of the structure. The layout of the structure and the arrangement for berthing and mooring should be studied to determine the critical loading situations due to lateral loads.

Environmental loads on piles, such as wave and current loads that vary along the length of the piles, should be included in the analysis of the critical loading combinations

3.3 Fenders

A fender system absorbs berthing energy, reducing the impact loads to the level that both the vessel and structure can safely sustain. The higher the energy absorption capacity, the more comfortable the berthing operations will be. The total effective energy of the berthing vessel is proportional to the square of the velocity of the vessel normal to the berth. The amount of energy to be absorbed by the fender system is the berthing energy multiplied by adjustment factors taking into account the eccentricity, softness and configuration of the berthing operation.

Guidance on the assessment of the energy to be absorbed by fenders and the berthing reaction is given in Section 5.12 in Part 1 of the Manual and BS6349: Part 4 (BSI, 2014). Table 7 gives a brief summary. The deformation characteristics of the fender system determine the berthing reactions for a given berthing energy. The following steps are required in the design of rubber fenders:

- Identify the types and sizes of vessels.
 - Prepare the preliminary layout of the fenders (see Figure 8).
 - Determine the vertical position of the fenders to accommodate vessels at different tidal levels.
 - Compute the berthing energy (see Table 7).
 - Select suitable type and shape of fenders (check suppliers' catalogues).
Assess the energy absorption, reaction and amount of deflection (check manufacturer's performance curves).
 - Check the fender arrangement to ensure that the vessel will not be in contact with the pier when the fenders are deflected (see Figure 5).
- Refine the fender design if necessary.

Where plastic fenders are used, it is necessary to determine whether the strength of the plastic fenders is adequate to transfer the berthing impact to the rubber buffers. The design of the rubber buffer is the same as a rubber fender. More details of the design of rubber and plastic fenders are given in Appendix A.

3.4 Moorings

Bollards should normally be fixed at the seaward end of transverse beams of pile bents, which are then designed to resist the mooring loads applied over a range of directions horizontally and vertically. Bollards should not be located on a beam-supported slab, as the slab would need to be heavily reinforced and thickened locally to resist the mooring loads. The size of the bollard, the amount of reinforcement inside it and the anchorage length of the reinforcement must be designed to allow transfer of the mooring loads to the pier. General guidance on the determination of mooring loads is given in Chapter 5 of Part 1 of the Manual. The following steps are required in the design of the mooring system :

- ⌘ Identify the types and sizes of vessels, and mooring points on the vessels.
- ⌘ Prepare the preliminary layout of the bollard locations (see Section 2.8 of this part of the Manual).
- ⌘ Determine the mooring loads (see Section 5.13 of Part 1 of the Manual) that may occur over a range of possible horizontal and vertical directions.
- ⌘ Design the bollard to resist the mooring loads.
- ⌘ Check the bollard arrangement and refine the mooring design if necessary.

In the design of the bollard and the load transferred to the pier, account should be taken of the vertical components of the mooring loads resulting from the mooring lines not being horizontal. For the purpose of design, a maximum angle of 30° to the horizontal (up and down) may be assumed, if no other information is available. The directions (both horizontal and vertical) of the mooring loads should be examined to determine the most critical loading effect on the pier.

Normally, the mooring system is designed to accommodate the wind and current forces on the vessels. At exposed locations, however, appreciable waves may exist and hence considerable loads may be developed in the vessels' moorings. These forces are difficult to analyze, and computer simulations, model testing, and/or field measurement will be required.

3.5 Structural Design

3.5.1 Pier Deck

The pier deck is commonly constructed in the form of a reinforced concrete frame structure consisting of beams and slabs supported by piles. Some typical pier deck cross-sections and

precast concrete construction are shown in Figures 9 and 10 and Plates 7 and 8.

Limit state design should be adopted for the reinforced concrete deck, using the partial factors for actions, combination factors and combination formulae for design situations given in Table A.1, Table A.2 and Table A.3 of Annex A of BS 6349: Part 2 (BSI, 2010), and using the partial factors for materials given in Clause 2.4.2.4 of BS EN 1992-1-1:2004 (BSI, 2004).

At the serviceability limit state, crack width anywhere in a concrete structure should be limited to a maximum of 0.3 mm. Reference should be made to Section 7.3 of BS EN 1992-1-1:2004 (BSI 2004). For concrete within the tidal and splash zones, it is recommended that crack widths under typical average long-term loading conditions should be limited to 0.1 mm. The typical average long-term loading conditions for each element of a structure will depend on the type of structure and its use, and should be assessed by the designer for each case. As general guidance, the typical average long-term loading should cover full dead and superimposed dead loads, combined with 50% to 75% of full live loads, using nominal or characteristic loads in each case. Berthing, mooring, wind and wave loads may be ignored because of their relatively short duration. The material properties such as modulus of elasticity for crack width calculations should be taken as those appropriate to the serviceability limit state under consideration.

The allowable crack width may be increased by a factor of 1.25 when the recommended specification for reinforced concrete in marine environment given in Appendix 21.2 of Section 21 of GS (HKSARG, 2020) is adopted.

3.5.2 Piles

Global factors of safety should be used when designing piled foundations of marine works against shear failure of the ground. The loads used should be unfactored values covered in Chapter 5 of Part 1 of the Manual, with no allowance for partial safety factors. When considering the interaction between the structure and the soil, all appropriate loading conditions should be examined. Reference should be made to GEO Publication No. 1/2006 – Foundation Design and Construction (GEO, 2006), GEO Technical Guidance Note No.41 (TGN 41) – Amendments to British Standards References in Technical Guidance Documents for Migration to Eurocodes (GEO, 2014) and Code of Practice for Foundations (BD, 2017).

For any pile, the ultimate bearing or pull-out capacity should be assessed from loading tests, and the working load should not be greater than the ultimate bearing or pull-out capacity, as appropriate, divided by a factor of safety. The required factors of safety are different

depending on whether preliminary piles as specified in GS Clause 8.42 are included in the pile loading tests. The minimum global factors of safety for piles in soil and rock are given in Table 6.1 of GEO Publication No. 1/2006 (GEO, 2006), which are summarized as follows :

<i>Method of Determining Pile Capacity</i>	<i>Minimum Global Factor of Safety against Shear failure of the Ground</i>		
	<i>Compression</i>	<i>Tension</i>	<i>Lateral</i>
Theoretical or semi-empirical method not verified by load tests on preliminary piles	3.0	3.0	3.0
Theoretical or semi-empirical method verified by sufficient number of load tests on preliminary piles	2.0	2.0	2.0

General guidance on the design of piled foundation is given in (GEO, 2006) and (GEO, 2014). Particular aspects of the design of piles for marine structures are given in Sections 8.11 and 8.12 of BS 6349: Part 2 (BSI, 2010). In particular, the following should be noted :

- The piles should be designed to resist loads from any possible direction, and non-symmetrical sections should be checked for biaxial bending.
- Where large loads are applied predominantly from one direction, the major axis of the pile should be orientated at right angles to it.
- The installation stresses may be a controlling factor in the choice of the pile size.
- Piles extending through water and/or soft soils should be designed to avoid failure by column buckling. Pile elements should be checked for local buckling arising from axial compression, bending and shear loading.
- Raking piles designed to resist vertical loads should be arranged in opposing pairs of equal batter, unless they are required simultaneously to resist a lateral load.
- Piles resisting lateral loads should be adequately embedded to obtain the required resistance from the soil.
- The point of fixity of piles in the soil should take into account any future deepening, scour or over-dredging. The point of fixity of piles in a slope should take into account the angle of the slope and the restraint due to any rubble protection provided.

- When lateral deflections associated with cyclic loads at or near the seabed are relatively large, consideration should be given to reducing or neglecting the skin friction of the pile in this zone.
- Unless temporary bracing is used, the effective length of piles during construction and testing is usually greater than that in the final condition. The allowable stresses due to loads applied prior to the completion of the connection between the piles and the deck may be limited by the temporary effective length.
- The loads applied during testing of piles should be taken into account in pile design, using the effective length of the pile at the testing stage.

Vertical movements of the pile heads due to deformation of the piles and the ground should be calculated for the dead and live loads together with any downdrag on the piles. Pile size and spacing should be adjusted to limit the movement, in particular, differential settlement of the deck and the resulting stresses occurring at the pile heads. Horizontal movement of pile heads should be assessed for each combination of maximum horizontal loads. The possibility of two adjacent structures deflecting in opposite directions should be considered. As well as considering the effect of movements of the pile heads on structural integrity, the effect on pier operations should also be investigated.

The stability of any slope under a piled deck pier should be analyzed for all critical loading conditions. Where long-term lateral soil loads would be exerted on the piles in a slope, ground improvement or suitable measures should be taken in advance of pile installation to avoid such loading.

Attention should be paid to the orientation and spacing of the piles to ensure that they will not hit each other during installation (see Figure 11) and will not be struck by vessels during berthing and mooring.

3.6 Corrosion Protection for Pier Deck

3.6.1 Corrosion Mechanism

Corrosion of steel reinforcement is the commonest defect found in reinforced concrete structures exposed to the marine environment. Corrosion of reinforcement is due to the movement of chloride ions from the surfaces of the concrete elements to the concrete immediately surrounding the reinforcing bars (see Figure 12). Corrosion occurs when the

chloride content exceeds the threshold value of about 0.06% by weight of concrete. The products of corrosion will occupy a volume of two to four times more than the original steel, causing cracking, spalling and delamination of concrete. Corrosion problems are usually at first only apparent in areas with higher concrete permeability or lower cover. The risk of corrosion is usually highest in the splash zone and tidal zone (see Figure 13).

General guidance on corrosion protection, including the recommended specification for reinforced concrete in marine environment, is given in Chapter 6 of Part 1 of the Manual. Further elaboration on specific aspects is given in the following sections. Life cycle cost analysis should be carried out before deciding which protection system is to be used.

3.6.2 Protective Coatings

The reinforced concrete within the tidal and splash zones will still be subject to chloride induced corrosion during the design life of the structure, even though the quality of the concrete has been enhanced by using the recommended specification for reinforced concrete. Hence, the reinforced concrete of new structures should be treated with a suitable coating to provide further protection against chloride ingress. Coatings not designed to be applied before concreting should preferably be applied immediately after removal of formwork in accordance with the manufacturer's recommendations so that the chloride concentration in the concrete will not reach critical level. If the chloride content at the reinforcement reaches the corrosion threshold value of 0.06% by weight of concrete, the application of coatings will be ineffective in preventing reinforcement corrosion.

A suitable coating must form a barrier against the physical and chemical factors that damage the concrete. Equally, there may be other reagents or physical conditions involved, which although not damaging the concrete, might cause deterioration of the coating. It is therefore necessary to know as much as possible about the chemical and physical conditions to which the coating will be exposed.

Other factors outside the service conditions have to be considered. Some coatings that cannot be applied in thick films may not be satisfactory on uneven concrete surface. The problem may be alleviated by filling out major surface imperfections with suitable filler but more often a high-build paint system is preferred to ensure effective protection of the substrate.

It is unusual for concrete to be coated in a single application. A primer is normally applied first to seal the surface. This is typically an unfilled resin dissolved in solvent. Its low

viscosity allows it to penetrate into the concrete and provide a good mechanical key for subsequent coats. It is also advisable to use multi-coat paint systems for concrete because greater film thickness will enable better overall protection and continuity of the application.

Relative humidity should always be taken into account when coating materials are selected. For example, some moisture-cured polyurethane paints tend to blister if the relative humidity of the substrate surface is too high. Water-based coatings will not cure properly in these conditions, because sufficient water evaporation cannot take place.

Surface temperature is also a concern. Many paint systems, particularly those based on epoxy resins, will cure only very slowly at low surface temperatures. Polyurethane and vinyl coatings are among those that are not so sensitive and may be used at lower temperatures.

There are various generic types of protective coatings available in the market. The most common types used in marine environment are epoxies and penetrants. Special attention should be paid to the following in choosing the appropriate type of coatings :

- Barrier coatings such as epoxies are applicable to slab soffits and concrete elements in splash and tidal zones. The disadvantage is that they require a high standard of surface preparation to achieve the necessary bond strength. The choice of colour is rather limited, as most of the epoxy products are black in colour and may not be appealing for application on exposed surfaces.
- Penetrants such as silane require the substrate to be relatively dry in order that they may penetrate the concrete to sufficient depth and in sufficient quantity. It is advisable to apply penetrants on precast units in a well-controlled environment such as a sheltered precast yard.
- Other generic types are also available such as acrylic and polyurethane. A combination of coatings may be used depending on the recommendations of the manufacturers and the results of site trial.

In general, the life of coatings is about 5 to 10 years. It is likely that re-coating at some stage is necessary as an ongoing maintenance commitment.

Wrapping with special fabric assisted by resin or bituminous binders has also been proven to be effective. If properly applied, the wrapping will provide an effective barrier to ingress of

water or aggressive ions into concrete. Wrapping with high tensile strength can provide extra strength to the concrete. Example applications are the use of carbon fibres or high tensile strength glass fibre.

3.6.3 Cathodic Protection

Cathodic protection is an effective means to stop reinforcement corrosion in marine structures. A pre-requisite requirement for the installation of cathodic protection system is to ensure that the embedded reinforcement is electrically connected.

Electrical continuity of the reinforcement should be checked during the construction stage prior to casting the concrete. The reinforcement should be checked for electrical continuity at a minimum frequency of 5 locations per 100 m² of concrete surface area. The check points should cover :

- Electrical continuity between starter bars of precast units and in-situ structures.
Electrical continuity of reinforcement within same element of precast or in-situ
- structures.
- Electrical continuity of reinforcement between elements of precast and in-situ
- structures.
- Electrical continuity of all metallic items, other than reinforcement, to the
- reinforcement itself.

Any discontinuity should be recorded, rectified and re-tested for electrical continuity before concreting.

3.6.4 Corrosion Monitoring

Corrosion monitoring devices should be installed in the reinforced concrete in order to monitor the corrosion conditions and the effectiveness of coating to prevent chloride ingress. These devices can provide useful information to forewarn the maintenance engineers when action needs to be taken against corrosion.

A typical corrosion monitoring system may consist of reference electrodes, multi-depth sensors and termination boxes. A reference electrode is a standard electrode attached to the reinforcement. The risk of corrosion is monitored by measuring the potential of the reinforcement relative to that of the reference electrode. In order to monitor the migration of the chloride ions in the concrete, a set of multi-depth sensors is placed within the concrete

cover to measure the corrosion current flow in various metallic rods of the sensors. The cables of the corrosion monitoring components are terminated at the termination boxes to enable recording of the signals.

Corrosion monitoring devices should be installed at representative locations on the structural elements where access is difficult for corrosion assessment and where significant chloride attack is likely, for example, the end wall of a pier with the greatest splash. Corrosion monitoring devices should also be placed on structural elements in different exposure zones where the extent of corrosion is likely to be different. A specialist's advice should be sought on the design of the corrosion monitoring system and interpretation of electrical data.

3.6.5 Protection for Steel Fixtures

Stainless steel of grade 316 or higher should be used for steel fixtures such as handrails, mooring eyes, chains and cat ladders, including bolts, nuts, washers and bearing plates as appropriate. Where the use of stainless steel is not practical, for example, in the case of structural steel elements or navigation light posts, steelwork should be hot-dip galvanized and coated with proprietary protective paints. Bitumen paint is usually applied to cast iron bollards to improve appearance. Protective paints should be applied in accordance with the manufacturer's recommendations. Particular attention should be paid to the importance of adequate surface preparation and if the painting is undertaken on site, the need to carry out the work in favourable weather conditions to avoid contamination from moisture in the air and salt spray. Regular repainting is necessary for durability and to avoid unsightly appearance from rust staining. Further information is given in Section 6.8 of Part 1 of the Manual.

3.7 Corrosion Protection for Piles

3.7.1 Steel Piles

For steel piles and structural steel elements, corrosion protection or allowances for metal losses due to corrosion should be catered for in the design. Hong Kong's waters are relatively warm and contain various pollutants whose effect on steel is generally unknown. In many sites, the presence of anaerobic sulphate-reducing bacteria, which can greatly increase the normal steel corrosion rate, is also suspected. In the absence of full scale long-term tests covering metal loss from corrosion, steel piles above seabed level, whether fully immersed, within the tidal or splash zones or above the splash zone, should be fully protected

against corrosion for the design life of the structure. To account for the uncertainty of corrosion below the seabed, corrosion protection should be extended to a minimum depth of 3 m below the seabed level. Below seabed, an allowance for corrosion loss of 0.05 mm per year is considered reasonable on the outside face of the piles without corrosion protection.

For temporary structures, with a design life not greater than 10 years, an allowance for corrosion loss of 0.5 mm/year may be assumed on the outside face of the piles below the tidal zone where there is no corrosion protection. At and above the tidal zone, full corrosion protection is strongly recommended, even for temporary structures.

3.7.2 Reinforced Concrete Piles

For reinforced concrete bored piles, the concrete should follow the marine concrete specification as given in Chapter 6 of Part 1 of the Manual and should be cast under dry condition with adequate compaction and curing as far as possible. The steel casing for forming the bored pile may act as a sacrificial casing as an additional benefit to provide corrosion protection for the concrete. The sacrificial casing should not be included in the design of the piles.

3.7.3 Corrosion Monitoring

Regular inspection on the integrity of the protective coatings of the piles and the extent of corrosion of the sacrificial casing, as appropriate, is essential to ensure the structural safety of the piers during the design life. For each pile, a sufficient number of measurements should be made at each level during each inspection, to ensure an overall assessment of the condition of the piles. For cathodic protection system, the inspection, monitoring and maintenance of the piles should be undertaken by a suitably qualified expert.

3.8 Catwalk

The catwalk connecting the shore and a piled deck jetty may be in the form of a concrete blockwork structure, a piled deck structure or a rubble mound structure, depending on the site conditions, configuration of the pier and other project considerations. Guidance on the design of a piled deck structure and a blockwork structure are given in this chapter and the next chapter, respectively. For a rubble mound structure, the structural design is similar to that for a rubble mound breakwater, given in Part 4 of the Manual. For a blockwork or rubble mound catwalk, openings may be introduced at appropriate intervals to enhance the

flow circulation. Mathematical modelling may be applied to determine the necessity of openings and the required spacing in the catwalk.

For a piled deck catwalk, the number of supports and foundations for the beams can be reduced if steel sections are used instead of reinforced concrete beams, because of the longer span that steel beams can sustain. The steel sections and the concrete deck slab may be designed in accordance with [BS EN 1992-1-1:2004 \(BSI, 2004\)](#) and [BS EN 1994-2:2005 \(BSI, 2005\)](#) to form composite construction. Adequate corrosion protection measures, such as enclosing the steel sections with concrete and coatings, should be applied to ensure the durability of the steel in marine environment. Where cathodic protection is to be installed, it is necessary to ensure electrical continuity of the steel sections and any embedded reinforcement. Refer to Section 3.6 of this part of the Manual for further details of corrosion protection. The designer should evaluate the suitability of this type of construction with respect to the project conditions.

3.9 Construction

3.9.1 General

This section addresses particular aspects of construction of piled deck piers. For information on the materials, workmanship, quality control and other construction aspects, refer to the General Specification for Civil Engineering Works (GS) ([HKSARG, 2020](#)).

3.9.2 Piling

The location of all temporary setting-out marks and the levels of all temporary tide gauges should be checked before any piling or construction works start on site. For a driven pile, the location and the rake of the pile should be checked after pitching but before driving commences, and for a bored pile, the location of the casing should be checked before any boring commences.

When checking the design of any temporary staging and temporary works, care should be taken to ensure that the effects of wind pressure, wave loads including possible uplift, dynamic or impact loads, construction materials, formwork and falsework, plant equipment and workmen have been taken into account in the design. Temporary staging for pile installation plant should take particular account of pile weights during pitching and during the installation of raking piles.

Section 8 of the GS requires all marine piles to be driven from fixed staging unless approved otherwise by the engineer. There is the likelihood of damage to piles driven from a barge, especially at exposed sites. Under certain circumstances, pile driving from a barge may be acceptable for relatively protected sites, particularly where steel piles are to be used. In such situations, large piling barges should be used so that barge movements are small and do not affect pile driving. In any case, pile driving from a barge should be stopped when the weather condition becomes rough.

The provision of temporary supports for driven piles during driving, and until incorporation into the superstructure, is covered in Section 8 of the GS. For marine piles, it is important to ensure that bracing to pile heads, in two directions at right angles, is provided immediately after driving, to prevent the possibility of oscillation in the cantilever mode due to currents and wave forces.

The tolerances for pile installation are given in Section 8 of the GS. In summary, the deviation of the pile centre at the cut-off level should be within 150 mm of the specified position in plan. The deviation of vertical piles from the vertical and the deviation of raking piles from the specified batter should not exceed 1 in 25. The deviation from the specified cut-off level should not exceed 25 mm. The design of piles and structural members should take account of these specified tolerances.

3.9.3 Pier Deck

The shape of the reinforced concrete elements should be as simple as possible to minimize construction difficulty over water. Congested reinforcement should be avoided, as this makes compaction of the concrete difficult and will inevitably reduce the durability of the concrete. Precast concrete should be used wherever possible and all concreting works should be carried out in dry conditions. Connection of too many precast concrete elements at the same location should be avoided, as this will usually result in difficulty in locating the precast elements to the required tolerance, due to conflicting reinforcement. Works should be carefully planned to ensure that all available working periods at low tide are efficiently used.

It is normal to delay the installation of fenders until the end of the construction period to reduce the possibility of damage by construction plant. Before incorporation in the works, each fender should be inspected for defects such as surface inclusions, pores and cracks. Any cast-in fixing bolts must be adequately protected against corrosion and damage prior to

the installation of fenders. When facilities such as lights, cables, pipes, lifts and ramps are to be installed by other agencies, particular attention should be paid to coordination of the different activities when preparing the construction programme.

3.10 Maintenance

Facilities such as access ladders, lifting hooks and mooring eyes should be provided for maintenance of the pier. For a piled deck pier, adequate headroom is necessary for inspection and repair works under the deck. Inadequate headroom may pose a safety hazard to maintenance personnel when waves pass through the pier. Proper access and working space should be provided below the deck to facilitate delivery of materials and tools, and for the erection of temporary working platforms. The layout of piles, columns, beams, bracing and slabs should be carefully planned to allow adequate access and working area to minimize difficulty in carrying out maintenance works. The access should also be located in such a way to avoid affecting berthing and mooring of vessels. Details should be agreed with the maintenance authority.

For aspects relating to the maintenance of piled deck structures, such as inspection techniques, testing and repair methods, refer to the Maintenance Manual for Marine Facilities (CED, 2003b).

4. SOLID PIERS

4.1 General

Typical components of a solid pier are shown in Figure 14. The pier can be founded on sand fill in a dredged trench or on seabed deposits strengthened by a ground treatment process such as deep cement mixing and stone columns. A rubble mound is normally built on the foundation. The functions of these components are summarized as follows :

- Sandfill – Provides foundation stability.
- Pell-mell rubble mound – Provides foundation stability.
- Backfill to seabed level – Enhances foundation stability.
- Bermstones – Prevents toe scour.
- Levelling stones – Provides a levelled bed for concrete blocks or caissons.
- Toe block – Evens out relatively high pressure at the toe.
- Concrete block or filled caisson – Provides wave protection and stability.
- Concrete paving – Forms a levelled surface for pier operations.

A solid pier derives its stability largely from its self-weight. Failure by overturning occurs when the overturning moment due to the disturbing forces exceeds the restoring moment due to the weight of the structure. Sliding takes place when the frictional resistance between the base of the structure and the foundation is insufficient to withstand the disturbing forces. Bearing capacity failure occurs when the contact pressure beneath the base of the structure exceeds the bearing capacity of the foundation. If slip surface develops in the structure or foundation, slip failure will occur. Furthermore, wave actions or eddies generated by the propellers of vessels can lead to toe scour or undermining. The failure mechanisms are shown in Figure 14.

The following steps are normally involved in the design of a solid pier :

- Determine the design conditions, such as the design life, return period of loads, type and dimensions of vessels, and operations and installations on the pier.
- Determine the layout of the pier, such as the shape and dimensions of the deck, deck level, orientation, arrangement of fenders and moorings, locations of facilities and installations, dimensions of pier superstructure.
- Determine the depth alongside the pier and if an access channel is required.
Design the fenders for the pier.
- Calculate the self-weight of the pier and the external forces, such as surcharge,

- live loads from pier operations, berthing and mooring loads, environmental loads including wind, wave and current loads, buoyancy and wave uplift.
- Determine the stability of the pier against overturning, sliding, bearing capacity and soil shear failure.
- Design toe protection for the foundation.
- Design the facilities to be installed on the pier.
- Design corrosion protection for structural members and pier facilities as appropriate.
- Refine detailed design of the pier.

This design sequence is subject to adjustment to suit the output of individual steps. Aspects on the design conditions and layout of the pier have been mentioned in Chapter 2 of this part of the Manual. Specific aspects on the determination of loading, stability analysis, toe protection and construction for solid piers are given in this chapter.

Solid piers may have significant adverse effects on the flow circulation of the nearby waters. The location and orientation of the pier should be determined with due consideration of the possible effects on the flow circulation. If possible, the pier should be oriented to avoid intersecting significantly any tidal flow.

4.2 Stability

Where soil properties have been tested and determined, the following minimum factors of safety against overturning, sliding, bearing capacity and soil shear failure may be adopted :

	<i>Normal Loading Conditions</i>	<i>Extreme/Accident Loading Conditions</i>
Overturning	2.0	1.5
Sliding	1.75	1.5
Bearing capacity	2.5	2.0
Soil shear slip failure	1.3	1.2

The above factors are global factors of safety.

For temporary loading conditions, the designer should assess the factors of safety required for each individual case.

For overturning, it is recommended that the resultant force should lie within the middle third of the base width under normal loading conditions when transient loads are ignored.

For sliding, the coefficient of friction at the interface of concrete and levelled rubble mound may be taken as 0.6. In the case of concrete blockwork structure, the factors of safety against sliding also apply to the horizontal interfaces between concrete blocks. The coefficient of friction at the interface of two concrete blocks may be taken as 0.6.

For soil shear failure along the slip surface, appropriate shear strength should be chosen for calculating the factors of safety under various loading conditions. If the foundation of the pier is to be founded on silty/clayey soil (low permeability), the undrained shear strength of the founding strata will be the controlling parameter for the short-term stability during construction and just after completion of the pier. The undrained shear strength can be determined from in-situ vane shear tests, using a reduction factor on the measured vane shear value, where appropriate. The unconsolidated undrained strength from triaxial tests may not be very reliable for assessing the stability due to the possible disturbance during soil sampling. For assessing the long-term stability of the foundation on low permeability soil, the shear strength determined from consolidated undrained triaxial tests with pore pressure measurement, or from consolidated drained triaxial or shear-box tests may be used.

The settlement that will occur during the design life of the pier should be assessed to ensure that this is acceptable in relation to the proposed use of the pier.

For solid piers made of reinforced concrete caissons, refer to Section 3.5.1 of this part of the Manual for the design of reinforced concrete.

4.3 Loading

4.3.1 Loading Conditions

Guidance on the loading conditions, including normal, extreme, temporary and accidental loading conditions, and the methods of assessment of the loads acting on a pier are given in Chapter 5 of Part 1 of the Manual. Other loading conditions that may be critical in the design life should also be investigated. Various types of loads should be combined in a way consistent with the probability of simultaneous occurrence. The loads for calculating the factors of safety should be unfactored values with no allowance for partial safety factors. [Reference should also be made to Section 5 of BS 6349: Part 2 \(BSI, 2010\).](#)

4.3.2 Water Levels and Waves

For a wharf backing on to the shore or reclaimed land, it is necessary to take into account the difference between the still water level in front of the wharf and the ground water profile behind as a result of tidal lag. Chapter 5 of Part 1 of the Manual recommends that a tidal lag of not less than 0.7 m above the still water level under normal loading conditions and 1.0 m under extreme loading conditions may be applied behind a seawall with simple ground conditions. On the basis of this assumption, the water levels and wave conditions shown in Table 8 should normally be considered in assessing the stability of a wharf. The ground water level should take into consideration the worst credible ground water conditions, for example, in the case where flow from land sources is significant.

For piers and jetties, tidal lag is not normally applicable, and the water levels and wave conditions shown in Section 5.10.2 of Part 1 of the Manual should be considered when assessing the stability.

However, under different loading cases and conditions, the critical still water level may be the minimum, maximum or some intermediate levels. Therefore, the full range of water levels should be investigated by the designer in addition to the water levels mentioned above.

4.3.3 Design Wave Height and Pressure

The design wave height for assessing the structural stability should be taken as the maximum wave height H_{max} .

For design purpose, to assess the wave pressure under a wave crest, H_{max} is generally taken as $1.8H_{1/3}$ if the structure is located seaward of the surf zone. Within the surf zone, the design wave height is taken as the highest of the random breaking waves H_{max} at a distance equal to $5H_{1/3}$ seaward of the structure as given by the Goda method in Appendix A of Part 1 of the Manual. The design wave period can be taken as the significant wave period. The corresponding wave pressure formulae according to Goda are given in Section 5.10.3 of Part 1 of the Manual.

To assess the wave pressure under a wave trough, the maximum wave height H_{max} is taken to be $1.8H_{1/3}$. It should be noted that the solution for wave pressure under a wave trough, in particular under a breaking wave, has not yet been fully developed. But as far as the pressure of standing waves is concerned, the wave pressure distribution under the trough may be determined according to the Sainflou theory as given in Section 5.10.3 of Part 1 of the

Manual.

Reference should be made to Section 5.10.2 of Part 1 of the Manual regarding the wave conditions to be considered in design. Typical wave conditions with respect to water levels are given in Table 8.

An impulsive wave pressure will be exerted on a vertical wall when incident waves begin to break in front of the wall and collide with it, having a wave front that is almost vertical. The impulsive pressure caused by breaking waves is much greater than the pressure usually adopted in the design of vertical structures mentioned above. Hence, these structures should be located in such a way to avoid direct exposure to impulsive breaking wave pressure. It is difficult to describe precisely the occurrence condition of the impulsive breaking wave pressure but the possibility of its generation may be judged to a certain extent with reference to the guidelines given in Table 9. It should be noted that the guideline is of a rather qualitative nature, and many cases may fall in the border zone. This uncertainty is inevitable because the phenomenon is affected by many factors in a complex and delicate manner. Physical model testing should be carried out if in doubt. Further guidance on the assessment of the impulsive breaking wave pressure can be found in Goda (2000).

4.3.4 Lateral Loads

For a pier/jetty, the critical case may include loads due to a wave crest acting on one side of the structure and a wave trough on the other side, and berthing on one side and mooring on the other side, depending on the wave direction, berthing and mooring arrangement. The critical case for a wharf may include the lateral earth pressure behind the wharf, the wave suction in front of the structure under the effect of a wave trough, and the mooring load from the vessel. Current load should also be considered if the pier will intersect significantly with the water current. A study of the layout of the structure and the arrangement for berthing and mooring is necessary to determine the critical loading situations due to lateral loads.

4.4 Toe Protection

Wave action in front of a structure can cause severe turbulence at the seabed. In particular, the toe of the structure can be exposed to the action of breaking waves in shallow water, leading to erosion of seabed material and scouring of the toe. The extent of toe protection and the rock size necessary to protect against wave action may be determined from Figure 15. Where currents are combined with wave action, it is suggested that the weight of the rock for

protection against wave scour be increased by 50% (BSI, 1991). Alternatively, the shear stresses due to the combined effect of waves and currents may be calculated to determine the required toe protection.

Guidance on the methods of protection against erosion due to eddies generated by vessel propellers is given in PIANC (1995).

4.5 Fenders and Moorings

Refer to Section 3.3 and Section 3.4 of this part of the Manual. In the case of reinforced concrete caissons, rubber fenders should be installed at the locations at which transverse partition walls meet with the outer walls.

4.6 Corrosion Protection

Concrete blockwork solid piers do not contain steel reinforcement and hence do not suffer corrosion problems due to ingress of chloride ions (see Section 3.6 of this part of the Manual). Defects are rare and mainly due to spalling arising from collision and abrasion by vessels. Regular inspection can be carried out less frequently than for reinforced concrete piled deck piers. Only patch repairs are required for the spalled areas.

For reinforced concrete caisson piers, corrosion of steel reinforcement may occur due to ingress of chloride ions, causing cracking, spalling and delamination of concrete if they are not properly protected from corrosion. Refer to Section 3.6 of this part of the Manual for details of corrosion control measures.

4.7 Catwalk

Refer to Section 3.8 of this part of the Manual.

4.8 Construction

4.8.1 General

This section gives comments on particular aspects related to the construction of solid piers. For information on the materials, workmanship, quality control and other construction aspects, refer to the General Specification for Civil Engineering Works (GS) (HKSARG, 2020).

4.8.2 Foundation

Unsuitable materials such as soft clay or silt should be improved by a ground treatment process such as deep cement mixing or stone columns (see Sections 4.5.2 and 4.5.3 in Part 4 of this Manual), or removed, either partially or wholly, by dredging and replaced with sand, to form a stable foundation. However, if dredging is proposed, the rationale for dredging must be agreed with Fill Management Committee first and chemical and possibly biological testing of the material will be required in order to determine the degree of contamination and whether it is suitable for disposal in confined or unconfined disposal facilities. Disposal requirements of dredged materials are given in ETWB TCW 34/2002 on Management of Dredged/Excavated Sediment (ETWB, 2002).

The dredge level for the foundation trench should be determined prior to construction based on adequate ground investigation. To ensure compatibility between design assumptions and actual site conditions, information on soil stratification and strength parameters revealed during construction must be compared to the predicted conditions. This can be achieved by sampling and testing the dredged material and conducting in-situ tests on material below the dredge line. This is absolutely essential if partial dredging is adopted. Measures to check the suitability of material below the dredge level as a foundation, including field and laboratory tests, should be identified in the design stage and specified in the contract. Field tests to assess the in-situ strength includes vane shear test, standard penetration test and cone penetration test as described in Chapter 4 of Part 1 of the Manual. Soil strength from field and laboratory tests must be compared with that obtained during the design stage. The design must be modified if differences are found. Analysis should also be made to the temporary stability of the dredged trench during construction.

Where thick layers of unsuitable materials are present, it may not be economical and environmentally friendly to undertake large scale dredging works to remove all such materials. In such case, it may be necessary to adopt piled foundation, after due

consideration of the site conditions.

To allow for subsequent settlement during the construction period, the levelling rock fill at the top of the foundation may be raised above the required design level. The amount may be calculated using methods described in Chapter 4 of Part 3 of the Manual. This amount of pre-set should be specified in the contract.

Where fill is to be deposited in a foundation trench, it is important to check that there has been no significant deposition or accumulation of soft deposits in the bottom of the trench after completion of dredging. This is particularly important when there has been a period of high waves during a storm. Such checking can be carried out by divers, grab sampling or additional hydrographic survey, or a combination of these, as appropriate. No fill should be placed until the dredged profile is agreed and approved. Where the designer considers that resiltation of clayey or silty particles of the dredged soil is a problem at a particular site, its effect on stability and settlement should be assessed.

4.8.3 Rock Armour and Underlayers

Rock in armour layers and underlayers should normally be placed from the bottom to the top of a section, in a manner and sequence such that individual rock pieces interlock and do not segregate and the interstices are kept free of small rock fragments. Each piece of armour should be placed individually, after inspection to ensure that it is within the specified weight range, uncracked and of acceptable shape. These requirements are particularly important as they relate directly to design assumptions covering stability against wave action. There should be no free pieces on the surface of a completed layer, and all pieces should be wedged and locked together so that they are not free to move without disturbing adjacent pieces in the same layer.

The core and underlayers are liable to damage by wave action during construction. It is advisable to limit the extent to which the core is constructed ahead of the underlayer, and the underlayer ahead of the armour, to reduce the risk of storm damage and consequent delay. If continuous rough weather is expected, it may be necessary to cease work before the onset of rough weather and provide temporary protection to the unfinished work. The armour layer should be placed as soon as possible following the placement of the underlayer to avoid damage to these layers, which may be difficult to repair. A sufficient number of pieces of rock armour should be kept in stock on site to allow rapid placement in case of an unfavorable weather forecast.

For rock armour layers and underlayers above water level, final visual inspections from the top of the slope and by boat from the bottom of the slope should be carried out in addition to the normal profile check by survey. Below water level, a final visual inspection by diver is recommended where possible, depending on visibility, particularly for rock armour layers. If any significant holes or areas with infilled interstices are detected, whether above or below water level, it will be difficult for these to be satisfactorily rectified without almost complete reconstruction of the adjacent areas. The number of rocks for a stated area specified in the drawings should be checked to ensure adequate coverage and thickness of the armour layer.

Bermstones should be placed as soon as practicable to protect the toe of the structure against scouring due to waves and currents. Underwater inspection is important to ensure that bermstones have been placed over the foundation width required and that the gap between bermstones is kept to the minimum.

4.8.4 Concrete Blocks and Caissons

Precast blocks for concrete blockwork structures are normally made of mass concrete with a characteristic strength of 20 MPa. The ease and accuracy of construction is dependent on the accuracy of the shape and size of the blocks being used and the accuracy and consistency of the levelling stones on top of the foundation. It is important for the levels of the rails or other profile marks to be checked by survey before laying of the levelling stones starts, and for the levelling stones to be inspected by diver before any block setting.

Concrete caissons consist of open-topped cells prefabricated in the dry and floated to their final location for sinking onto a prepared seabed foundation. Caissons are generally of rectangular shape in plan and subdivided into cells for strength and for control of stability during towing, sinking and filling when in the final position. Filling should be carried out as soon as the caisson is positioned for the sake of stability. Scour protection should be completed as soon as possible after placing of the caissons.

Key joints are sometimes necessary to transmit loads between caissons to avoid differential movement. They should be capable of transmitting 25% of the maximum horizontal load on either caisson to the adjacent unit (BSI, 1991). Except where caissons are placed on a rock foundation, some relative settlement is likely to take place and joints should provide for vertical movement. Gaps between caissons should generally be closed by joint sealant and filler to protect the bedding layer from scour due to high velocity currents.

The construction of in-situ concrete capping should preferably be carried out as late as possible in the construction programme in order to allow for settlement. The fill inside the caissons should be properly compacted before concreting of the capping, in order to maximize the weight (and hence the stability) and to provide a firm base for the operations on the pier deck.

4.8.5 Pier Facilities

The installation of fenders should be carried out at the end of the construction period to reduce the possibility of damage by construction plant. Any cast-in fixing bolts must be adequately protected against corrosion and damage prior to the installation of fenders. When facilities such as lights, cables, pipes, lifts and ramps are to be installed by other agencies, particular attention should be paid to coordination of the different activities when preparing the construction programme.

4.9 Maintenance

The maintenance of a solid pier is normally less complicated than that of a piled deck pier, as the inspection and repair works of the structure generally take place on the vertical face of the pier. Facilities such as access ladders, lifting hooks and mooring eyes should be provided to facilitate the maintenance works.

5. DOLPHINS AND FLOATING PIERS

5.1 Dolphins

5.1.1 Functions

A dolphin is an isolated structure or strong-point used either to manoeuvre a vessel or as a mooring. Dolphins may be used in combination with piers to shorten the length of the piers. There are generally two types of dolphins, namely, berthing (or breasting) dolphins and mooring dolphins.

Berthing dolphins are designed to take the berthing impact of the vessel and to hold the vessel against the action of wind and current. Mooring dolphins are designed for mooring and not for berthing of vessels. They are usually located some distance behind the berthing face of the pier. Depending on the berthing and mooring layout, it is possible for a dolphin to be used for both berthing and mooring purposes. Dolphins may be provided in a typhoon shelter for mooring purpose and as navigation markers to demarcate different anchorage areas (see Plate 9). Dolphins may also be used as navigation markers in fairways.

5.1.2 Layout

A typical layout of a pier, or more specifically a jetty, with one berth consisting of a loading platform and berthing and mooring dolphins, is shown in Figure 16. The loading platform is not designed primarily for berthing and therefore it should be located behind the face of the berthing dolphins. The spacing of the berthing dolphins should normally lie within the range of $0.25L$ to $0.4L$, where L is the overall length of the vessel (BSI, 2014). Mooring dolphins for breast lines should usually be located near the bow and stern of the vessel at a distance of about 35 to 50 m from the longitudinal axis of the vessel to the centre of the mooring dolphin to avoid making the moorings too steep (BSI, 2014). If the pier needs to serve vessels of different lengths, the locations of the dolphins will be a compromise unless another set of dolphins is provided. The exact location of the dolphins should be agreed with the pier and vessel operators, and Marine Department's advice should be sought as appropriate.

The location, number and spacing of dolphins in typhoon shelters and fairways should be determined in consultation with the Marine Department.

5.1.3 Structural Design

Dolphins can be classified structurally as flexible dolphins or rigid dolphins. A flexible dolphin usually comprises only vertical piles built into a concrete cap or braced frame and deck whereas a rigid dolphin comprises a group of raking piles, with or without vertical piles, connected to a concrete cap. The flexibility of the structure should be considered in relation to the soil conditions, its function and type of operations to be carried out at the berth.

Flexible dolphins used as berthing dolphins absorb the berthing energy by deflection of the pile heads horizontally. However, the soil conditions must be capable of providing fixity with a reasonable embedded length. There must also be no permanent deflection after application of a berthing load. Flexible berthing dolphins may not be suitable if handling operations take place on the dolphins. Mooring dolphins should be rigid in order that the tension in the vessel's mooring lines is maintained.

The design of piled dolphins is similar to the design of piled deck piers given in Chapter 3 of this part of the Manual. Further design information is given in BS6349: Part 2 (BSI, 2010). In particular, the following points should be noted :

- For flexible dolphins, berthing loads applied at the corner of the structure will result in torsion. The torsion may be reduced by judicious positioning of the fenders, or be made use of by providing torsional strength in the piles to increase energy absorption. The piles, however, should be adequately embedded to obtain adequate lateral and shear resistance.
- For rigid dolphins, the rake of the piles should be as large as possible for maximum efficiency in resisting lateral loads. However, raking piles should not project into locations where they may be struck by vessels. Where downdrag on the raking piles may occur due to soil settlement, the resulting stresses set up in raking piles may be very large and should be taken into account in the pile design. The elastic centre of the pile group should lie as close to the resultant applied load as possible to reduce the likelihood of rotation and torsional loading on the pile. If the applied load induces a considerable moment about the elastic centre of the pile group, pile axes should preferably be arranged so that they intersect in groups at least at two locations on plan which should be as widely spaced as possible. The resultant applied load should pass between these locations.

Rigid dolphins may be of solid construction, for example, using concrete caissons. The stability requirements for solid piers given in Chapter 4 of this part of the Manual also apply to the design of solid dolphins.

Fenders must be provided at berthing dolphins, but fenders should also be provided at mooring dolphins to avoid damage from accidental impact.

5.1.4 Accessories

Access walkways should be provided from the jetty head to the dolphins. They should be positioned to avoid damage by vessels. Alternatively, isolated dolphins can be equipped with access ladders on a face away from berthing vessels. Dolphins should be provided with a platform of adequate working space for operational and maintenance purposes. A clear space should be left at the ends of walkways and heads of ladders. Railings and fences should be provided as appropriate. The type of installations on dolphins, such as navigation lights, should be agreed with the vessel and pier operators as well as the Marine Department as appropriate.

5.2 Floating Piers

5.2.1 Layout

A floating pier consists of a pontoon, an anchorage system and an access bridge connected to a seawall or an abutment at the shore. If the pier is located in a harbour, typhoon shelter or area not exposed to strong waves, a floating pier may be appropriate in the following situations :

- The site does not allow the construction of a fixed structure.
- The pier needs to be available for commissioning quickly.
- The pier is of a temporary nature.

A floating pier is considered as a moored pontoon (see Plate 10). It is normally box-shaped and constructed as a vessel's hull with longitudinal and transverse bulkheads. These bulkheads increase the strength of the pontoon and serve to subdivide the pontoon into compartments where machinery, pumps and ballast tanks are placed. The bulkheads also serve to contain accidental damage locally and therefore avoid uncontrolled sinking or capsizing of the pontoon.

A floating pier may be kept in position by anchor chains as shown in Figure 17. The chains are fastened in wells, which go through the pontoons. From the deck, there is access to the wells for adjustment of the length of the anchor chains. If this anchorage system is adopted, particular attention should be paid to avoidance of the anchor chains interfering with berthing vessels. An alternative, to limit the motion of a floating pier, is to connect the mooring lines to mooring rings which can float freely along fixed vertical sliding rods to cater for any tidal condition. The locations of the vertical sliding rods should not affect the berthing and mooring operations. An example of the latter arrangement is shown in Figure 18.

The width of a floating pier depends not only on the number of passengers or the amount of cargo to be handled, but also on the stability with respect to uneven distribution of live load. The length of the pier depends on the length of the vessels to be accommodated and, for reasons of wave conditions not only at the site but in particular during towing operations, it may be necessary to build the pier in sections which are hinged together on site. Fenders must be provided at the berthing faces of the pontoon. Lifesaving equipment should be provided on the floating pier.

5.2.2 Design Principles

The pontoon should be designed by a naval architect and built in accordance with the rules and regulations of a ship classification society and standards approved by the Marine Department. The following parameters should normally be specified for the design of the pontoon :

- Dimensions of the pontoon, including length overall, beam and operation freeboard.
- Type and size of vessel berthing at the pier.
- Passenger carrying or cargo handling capacity.
- Wind, wave and current conditions at the site.
- External loads acting on the pier.
- Requirements of access bridge and gangway.
- Type of facilities and installation to be provided on the pier deck.

Access from the shore to a floating pier can be arranged in different ways but one common method is to provide an access bridge that is able to accommodate the movements of the

pontoon. The dimensions and inclination of the access bridge should ensure that the passenger boarding or cargo handling capacity of the floating pier is not reduced by the presence of the bridge.

A cathodic protection system, usually self-energized, should be installed on the pontoon against corrosion of the steel elements. The actual number, size and position of the anodes and method of securing should normally be decided in consultation with the manufacturer of the anodes.

5.2.3 Testing

The floating pier should be subject to a series of test after its completion. These include hydrostatic test to ensure the water-tightness and strength of the pontoon, hydraulic test for piping systems, inclining experiment and light ship check for stability, hoisting and lowering test of the access bridge or gangway, and other electrical fittings inspection, as specified by the Marine Department. Any defect should be corrected before acceptance.

6. AESTHETICS

6.1 Principles

Various aspects affecting the aesthetic setting of the pier should be studied before proceeding with the detailed design. These include the prominence of the area where the structure will be located, characteristics of the existing waterfront, cultural, heritage and tourism considerations, functions and usage frequency of the pier, future development of the waterfront, complexity of the aesthetic works as well as the construction cost and ease of maintenance. The expectations of the local community should also be considered. Suitable architectural layout, roof, colour scheme, surface finishes, materials, lighting, furniture and associated accessories should then be determined to match with the chosen aesthetic setting of the pier.

Alternative proposals should be prepared and compared to determine an aesthetically pleasing solution. Attention should be paid to the visual quality and compatibility of individual components and facilities on the pier, their compatibility with the surrounding landscape and visual value, their relative positions and the interface details between the pier and the shore or adjacent facilities. The advice or input of an architect or a landscape architect is usually necessary in the process. Computer graphics and photo-montages are useful for obtaining a visual impression of both the external and internal appearance of the pier.

6.2 Illustrations

Several pier designs with differing aesthetics are shown in Plates 11 to 16.

The Pak Sha Wan Public Pier (Plate 11) in Sai Kung is an L-shaped pier serving kaitos to the surrounding islands. The wing-like roof structure symbolises the seagulls flying around the pier. A sitting area with similar appearance was also provided. A pattern was imprinted on the paving of the pier deck to enhance the overall appearance.

The Hei Ling Chau Public Pier (Plate 12) is an L-shaped jetty serving kaitos and local fishing boats. The roof of the jetty was designed to resemble a temple to match an existing Chinese pavilion on the shore. The use of glass roof allows natural light to penetrate to the pier deck. The roof structure is light green in order to harmonize with the whole area.

The Wu Kai Sha Public Pier (Plate 13) is located adjacent to a youth village. In view of the natural surroundings, the undulating roof profile was evolved to match the sea and the mountains. Supported by light blue columns, the wavy roof structure contributes to the pleasant ambience of the camp site nearby.

The Cheung Chau Public Pier (Plate 14) is located at the busy island waterfront. The pier deck, sheltered by the bazaar-like fabric roof, provides a physical and visual extension of the existing street market at the waterfront. This roof structure, being visible from a distance both in the daytime and at night, is complementary to the existing site context and becomes a feature at the promenade.

In Kat O Chau, there are many Chinese traditional village houses. In order to harmonize with the surrounding context, the Kat O Chau Public Pier (Plate 15) was designed with pitched wooden roofs and brick columns. Both timber and brick are common building materials in Chinese historical vernacular architecture and this design created a landmark associated with the cultural heritage of the island.

The ferry pier shown in Plate 16 is located at the waterfront of Central District. It was designed with a glass wall at the pier head to match the setting of the commercial buildings behind.

For solid piers, facing stones or suitable finishes may be placed on the vertical face of the structure above the water level to improve the appearance of the surface.

6.3 Durability

The durability of the materials plays an important role in the aesthetics of the pier. The pier may become unsightly quickly if materials deteriorate or are easily damaged by operations at the pier. Some measures to avoid this are suggested in the following paragraphs.

For a piled deck pier, corrosion of the sacrificial steel casings may give a false impression that the piled foundation is deteriorating. The application of a coating on the steel casings at the periphery of the structure which can be seen by the public, will allay such an impression, although this may slightly increase the cost of the foundation. For the purpose of improving the aesthetics, it is sufficient to apply the coating down to the low water level.

Rusting of steel fixtures or ducts can induce stains on the pier surface. Such stains are

difficult or impossible to remove. Proper detailing is necessary to avoid rust staining the surface, and stainless steel or materials not subject to corrosion should be used where appropriate. Joints should be carefully designed to prevent leakage. Drip lines should be provided at soffits and other appropriate locations to avoid wash-water staining.

Reinforced concrete in the marine environment, if not properly protected, will crack, spall and even delaminate due to chloride induced corrosion of the reinforcement. It is difficult to recover the texture and appearance of the original sound concrete surface even after repair. Protective measures, described in Section 3.6 of this part of the Manual, should be applied to enhance the durability of concrete.

Congested reinforcement should be avoided so that concrete can be easily placed and compacted. Where possible, precast concrete should be used, as quality control is difficult within the tidal and splash zones.

The shape of pier elements that are subject to frequent use should be detailed in such a way as to avoid damage from wear and tear or poor operational practice. The fixing details should be simple as far as practicable to facilitate installation and future repair and replacement.

Aesthetic features that may easily be damaged by vandalism should be avoided in the design, as this will result in increased maintenance cost.

REFERENCES

BD (2017). Code of Practice for Foundations. Buildings Department, Hong Kong.

BSI (1991). Maritime Structures – Part 7: Guide to the Design and Construction of Breakwater (BS 6349: Part 7: 1991). British Standards Institution, London, 88p.

BSI (2000). Maritime Structures – Part 1: Code of Practice for General Criteria (BS 6349: Part 1: 2000). British Standards Institution, London, 189p.

BSI (2002). Eurocode – Basis of Structural Design (BS EN 1990:2002+A1:2005) and its respective UK National Annex. British Standards Institution, London.

BSI (2004). Eurocode 2: Design of Concrete Structures – Part 1-1: General Rules and Rules for Buildings (BS EN 1992-1-1:2004) and its respective UK National Annex. British Standards Institution, London.

BSI (2005). Eurocode 4 – Design of Composite Steel and Concrete Structures – Part 2: General Rules and Rules for Bridges (BS EN 1994-2:2005) and its respective UK National Annex. British Standards Institution, London.

BSI (2010). Maritime Works – Part 2: Code of Practice for the Design of Quay Walls, Jetties and Dolphins (BS 6349-2:2010). British Standards Institution, London.

BSI (2014). Maritime Works – Part 4: Code of Practice for Design of Fendering and Mooring Systems (BS 6349-4:2014). British Standards Institution, London.

CED (2003a). Special Project Report No. SPR 1/2003 – Study on Coastal Subsoil Geotechnical Conditions. Civil Engineering Office, Civil Engineering Department, Hong Kong.

CED (2003b). Maintenance Manual for Marine Facilities. Civil Engineering Office, Civil Engineering Department, Hong Kong.

CETN (1988). Design of Rubble Foundation and Rubble Toe Protection (Coastal Engineering Technical Note (CETN-III-39, 3/88)). US Army Corps of Engineers.

- EPD (1997). Technical Memorandum on Environmental Impact Assessment Process. Environmental Protection Department, Hong Kong, 83p.
- ETWB (2002). Environment, Transport and Works Bureau Technical Circular (Works) No. 34/2002 – Management of Dredged/Excavated Sediment. Environment, Transport and Works Bureau, Hong Kong.
- GEO (2001). Model Specification for Soil Testing. Geotechnical Engineering Office, Hong Kong, 391p.
- GEO (2006). GEO Publication No. 1/2006 – Foundation Design and Construction. Geotechnical Engineering Office, Hong Kong.
- GEO (2014). GEO Technical Guidance Note No. 41 (TGN 41) – Amendments to British Standards References in Technical Guidance Documents for Migration to Eurocodes. Geotechnical Engineering Office, Hong Kong.
- GEO (2017a). Guide to Site Investigation (Geoguide 2) (Continuously Updated E-Version released on 18 December 2017). Geotechnical Engineering Office, Civil Engineering and Development Department, HKSAR Government, 349 p.
- GEO (2017b). Guide to Rock and Soil Descriptions (Geoguide 3) (Continuously Updated E-Version released on 29 August 2017). Geotechnical Engineering Office, Civil Engineering and Development Department, HKSAR Government, 171 p.
- GEO (2017c). Model Specification for Soil Testing (Geospec 3) (Continuously Updated E-Version released on 29 August 2017). Geotechnical Engineering Office, Civil Engineering and Development Department, HKSAR Government, 324 p.
- Goda Y. (2000). Random Seas and Design of Maritime Structures. World Scientific Publishing Co Pte Ltd, Singapore, 443p.
- HKSARG (2020). General Specification for Civil Engineering Works, 2020 Edition. The Government of the Hong Kong Special Administrative Region, 2 volumes.
- HKU (1998). Study of Inner Harbour Waves and their Reduction – Wave Loading Determination for Wave Absorbing Seawalls. University of Hong Kong.

- OCDI (2002). Japanese Technical Standards for Port and Harbour Facilities with Commentary (1999 Edition). Overseas Coastal Development Research Institute, Tokyo, 599p.
- PIANC (1995). Port Facilities for Ferries – Practical Guide. Permanent International Association of Navigation Congresses, Brussels, 40p.
- Tanimoto, K., Yagyu, T., and Goda, Y. (1982). Irregular wave tests for composite breakwater foundations, Proc. 18th Int. Coastal Eng. Conf., ASCE, Cape Town, pp. 2144-2163.
- TD (2003). Transport Planning and Design Manual Volume 9. Transport Department, Hong Kong.

TABLES

LIST OF TABLES

Table No.		Page No.
1	General Characteristics of Waves Generated by Various Types of Vessels	69
2	Comparison of Solid Piers and Piled Deck Piers	70
3	Comparison of Fendering Systems	70
4	[Not used]	71
5	Comparison of Various Forms of Long Strip Rubber Fenders	72
6	Testing Standards of Plastic Fenders	72
7	Assessment of Berthing Energy	73
8	Typical Water Levels for Design of Solid Wharfs	74
9	Assessment of Possibility of Impulsive Breaking Wave Pressure	75

Table 1 General Characteristics of Waves Generated by Various Types of Vessels

Vessel Types	Wave Characteristics
Monohull passenger ferries	<ul style="list-style-type: none"> ◆ They generate various intensities of water waves. Fast vessels with powerful engines generate strong waves which propagate over a relatively large area. Double or triple deck passenger ferries sailing at relatively low speed generate insignificant waves which attenuate to the background water level quickly after their formation.
Hover ferries	<ul style="list-style-type: none"> ◆ These vessels, which float over water on a cushion of air, have a shallow draft and travel at high speed. The waves generated are strong and have dominant diverging wave groups which can propagate over long distance.
Catamaran ferries	<ul style="list-style-type: none"> ◆ These vessels, with two parallel hulls coupled by a single deck, are designed for high speed navigation and are equipped with powerful turbo engines which can drive the vessels to over 40 knots. High speed results in predominant diverging wave groups in catamarans' wave system propagating away from long breaking wakes and covering a very large area.
Hydrofoils	<ul style="list-style-type: none"> ◆ The hulls of the hydrofoils are separated from the water surface under normal cruising. As such, hydrofoils do not generate strong waves because of the small resistance on the supporting wings. However, during departure from and arrival at a pier, the hulls are not separated from water and waves generated by hydrofoils in such conditions are very strong. Hence, in the neighbourhood of piers used by hydrofoils, waves generated by hydrofoils make a substantial contribution to the local wave field.
Tug boats	<ul style="list-style-type: none"> ◆ Tug boats are of wide beam, deep draft, and are usually equipped with powerful engines ranging from a few hundreds to over a thousand horse power. Unloaded, full speed tug boats generate strong waves which affect moving vessels in the surrounding area. Waves associated with tug boats consist of significant transverse waves and diverging waves with large waves occurring around the boundary of the wave propagation wedge.
Derrick lighters/barges	<ul style="list-style-type: none"> ◆ Cargo or containers are transported by lighters or barges with derricks towed by a tug boat with low navigation speed. Waves generated by these vessels are normally not significant to the wave field in the harbour.
Ocean-going containers	<ul style="list-style-type: none"> ◆ Ocean-going container ships approach the port of Hong Kong mostly at the eastern and western ends of the harbour. The speeds of these vessels are low and the vessel-generated waves are relatively small in comparison to the waves due to normal cruising in the ocean. Waves due to ocean-going container ships do not affect the harbour wave field significantly.
Self-powered river trade vessels	<ul style="list-style-type: none"> ◆ A wide variety of vessels characterized by types, speeds, sizes and displacement for cargo transportation are operated in the harbour. They generate waves with different propagation patterns. For cargo vessels navigating at low speed, waves generated usually make only a temporary contribution to the wave field in the harbour.
Service and engineering launches	<ul style="list-style-type: none"> ◆ These vessels include police boats, fire-fighting boats, pilot boats and various other utility crafts. Most of them can generate significant waves because of their speeds.

Table 2 Comparison of Solid Piers and Piled Deck Piers

	Solid Piers	Piled Deck Piers
Construction Period	♦ Shorter usually	♦ Longer
Construction Cost	♦ Lower usually	♦ higher
Environmental Impact	♦ sediment plume generated if foundation is dredged and flow circulation affected	♦ noise generated during piling
Operation	♦ vessel berthing affected by wave reflected from vertical face; wave absorbing device may be provided to reduce reflection	♦ no operation problem from wave reflection
Maintenance	♦ low maintenance	♦ significant maintenance for reinforced concrete and piled foundation

Table 3 Comparison of Fendering Systems

	Timber fenders	Plastic fenders	Rubber fenders
Strength	♦ low strength ♦ moderate abrasive resistance	♦ strength similar to timber ♦ high abrasive resistance	♦ strength designed to specific requirements ♦ high abrasive resistance
Durability	♦ subject to rotting, marine borer attack ♦ cracks will develop in insufficiently seasoned timber	♦ resistant to most biological and chemical attack, ultraviolet exposure and corrosion ♦ longer service life than timber fenders	♦ resistant to most biological and chemical attack, ultraviolet exposure and corrosion ♦ longer service life than timber fenders
Energy absorption capacity	♦ low energy absorption capacity ♦ high contact pressure	♦ moderate energy absorption capacity ♦ high contact pressure	♦ moderate to high energy absorption capacity
Environment	♦ consumption of tropical hardwood	♦ use of recycled material, more environmentally friendly	♦ use of natural/synthetic rubber, more environmentally friendly
Cost	♦ lower initial cost but higher maintenance cost	♦ higher initial cost but lower maintenance cost relative to timber fenders	♦ higher initial cost but lower maintenance cost relative to timber fenders
Supply	♦ specific hardwood to meet the strength requirements.	♦ plastic fenders with or without fibre glass reinforcement available	♦ a wide range of products available

Table 4 [Not used]

Table 5 Comparison of Various Forms of Long Strip Rubber Fenders

Fenders	Circular fenders	D fenders	Arch fenders	Turtle fenders
Common sizes (Height of Section)	♦ 150, 200, 250, 300 mm & above	♦ 150, 200, 250, 300 mm & above	♦ 200, 250, 300 mm & above	♦ 150 & 200 mm
Typical characteristics	♦ relatively low energy absorption ♦ soft contact and low reaction force	♦ relatively low energy absorption ♦ soft contact and low reaction force	♦ relatively high energy absorption by compression of fender ♦ robust installation	♦ relatively high energy absorption by provision of stiffeners ♦ larger breadth to height ratio: lower contact pressure & less damage under severe mooring, upper end closed & inclined to avoid snagging, robust installation
Mounting	♦ loosely mounted and supported on chains	♦ fixed directly on seawall by bolts; fixing methods dependent on required robustness	♦ fixed directly on seawall by two rows of bolts	♦ fixed directly on seawall by two rows of bolts
Note : The above information is subject to change due to development of new products in the market.				

Table 6 Testing Standards of Plastic Fenders

Material	Physical Properties	ASTM Standards
Plastic	Density	ASTM D792
	Water absorption	ASTM D570
	Impact resistance	ASTM D746
	Hardness	ASTM D2240
	Ultraviolet resistance	ASTM D4329
	Abrasion resistance	ASTM D4060
	Coefficient of friction	ASTM F489
Fibreglass reinforcement	Tensile property	ASTM D638
	Flexural property	ASTM D790
	Compressive property	ASTM D695

Table 7 Assessment of Berthing Energy

Energy to be absorbed by fender system under normal loading conditions :		
$E = 0.5 C_M M_D V_B^2 C_E C_S C_C$ (kNm)		
Parameter		Unit
C_M	Hydrodynamic mass coefficient	-
M_D	Displacement of vessel	t
V_B	Berthing velocity of vessel normal to the berth	m/s
C_E	Eccentricity coefficient	-
C_S	Softness coefficient	-
C_C	Berth configuration coefficient	-
D	Draft of vessel	m
B	Beam of vessel	m
Notes:		
1. For the determination of berthing velocity and various coefficients, refer to Section 5.12 Part 1 of the Manual.		
2. For accidental loading conditions, E should be increased by :		
50% (structures of general use)		
100% (structures which are critical, heavily used or located in exposed waters)		
3. Berthing loads are not normally considered under extreme loading conditions except for effects arising from temperature variations.		

Table 8 Typical Water Levels for Design of Solid Wharfs

Loading Conditions	Wave Condition	Still Water Level in front of Wharf	Ground Water Level behind Wharf
Normal/ Accidental	Wave condition at tropical cyclone signal no. 3 or within the first few hours of hoisting of tropical cyclone signal no. 8	Sea water level at return period of 2 years	Sea water level at return period of 2 years
		Sea water level at return period of 2 years minus 0.7 m	
		Mean lower low water level	Mean lower low water level plus 0.7 m
Extreme	Wave condition at return period of 100 years	Sea water level at return period of 10 years	Sea water level at return period of 10 years
		Sea water level at return period of 10 years minus 1.0 m	
	Wave condition at return period of 10 years	Sea water level at return period of 100 years	Sea water level at return period of 100 years
		Sea water level at return period of 100 years minus 1.0 m	
	Wave condition at return period of 50 years	Sea water level at return period of 50 years	Sea water level at return period of 50 years
		Sea water level at return period of 50 years minus 1.0 m	
	Wave condition at return period of 100 years	Mean lower low water level	Mean lower low water level plus 1.0 m
	Notes : 1. The water levels for temporary loading conditions should be determined by the designer. 2. The critical still water level may be some intermediate level between the quoted water levels in this table and should be assessed by the designer for each case. 3. The designer should take into account the worst credible ground water condition when determining the ground water levels behind the wharf. Hence, the design ground water level may be higher than the levels given in this table.		

Table 9 Assessment of Possibility of Impulsive Breaking Wave Pressure

A-1	Is the angle between the wave direction and the line normal to the breakwater less than 20° ?	—No → Little Danger
	↓ Yes	
A-2	Is the rubble mound sufficiently small to be considered negligible?	—No → Go to B-1
	↓ Yes	
A-3	Is the sea bottom slope steeper than $1/50$?	—No → Little Danger
	↓ Yes	
A-4	Is the steepness of the equivalent deepwater wave less than about 0.03?	—No → Little Danger
	↓ Yes	
A-5	Is the breaking point of a progressive wave (in the absence of a structure) located only slightly in front of the breakwater?	—No → Little Danger
	↓ Yes	
A-6	Is the crest elevation so high as not to allow much overtopping	—No → Little Danger
	↓ Yes	
	<div style="border: 1px solid black; padding: 5px; width: fit-content; margin: 0 auto;"> Danger of Impulsive Pressure Exists </div>	
	(Continued from A-2)	
B-1	Is the combined sloping section and top berm of the rubble mound broad enough?	—No → Little Danger
	↓ Yes	
B-2	Is the mound so high that the wave height becomes nearly equal to or greater than the water depth above the mound?	—No → Little Danger
	↓ Yes	
B-3	Is the crest elevation so high as not to cause much overtopping?	—No → Little Danger
	↓ Yes	
	<div style="border: 1px solid black; padding: 5px; width: fit-content; margin: 0 auto;"> Danger of Impulsive Pressure Exists </div>	

Source : Reproduced from “Random Seas and Design of Maritime Structures” by permission of Prof. Y. Goda.

FIGURES

LIST OF FIGURES

Figure No.		Page No.
1	Layout of Piers	81
2	Degree of Freedom of Vessel Movement	81
3	Rubber Fenders	82
4	Plastic Fenders	83
5	Fender Arrangement	84
6	Mooring Arrangement	85
7	Flexible and Rigid Piled Deck Structures	86
8	Fender Spacing	87
9	Cross-Section of Reinforced Concrete Piled Deck Pier	88
10	Precast Concrete Construction for Piled Deck Pier	89
11	Piling Layout	89
12	Corrosion Process of Reinforcement	90
13	Vertical Zoning of Marine Environment	90
14	Key Elements and Failure Mechanism of Solid Pier	91
15	Toe Protection	92
16	Layout of Dolphin	93
17	Floating Pier with Anchor Chain	94
18	Floating Jetty	95

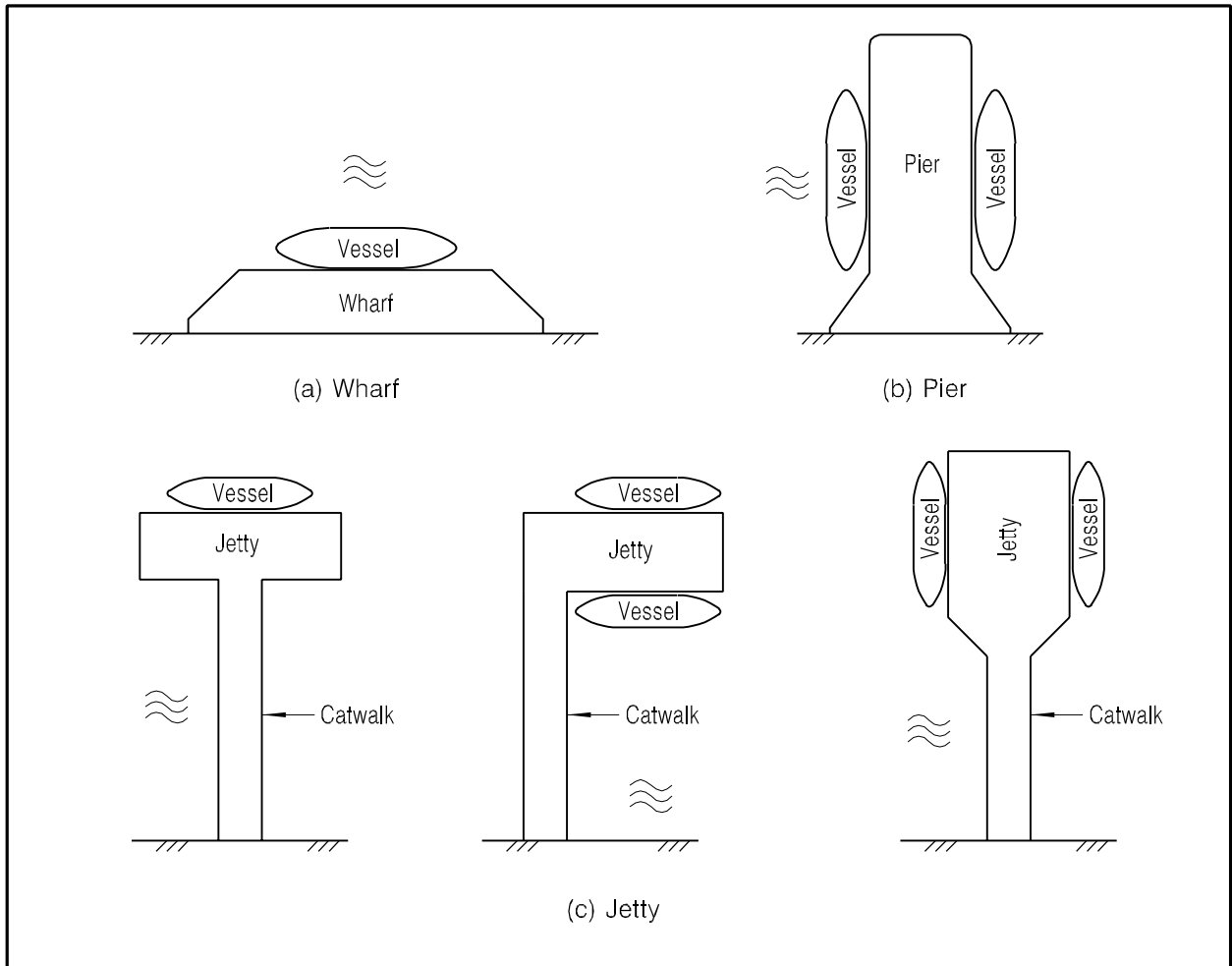

Figure 1 – Layout of Piers

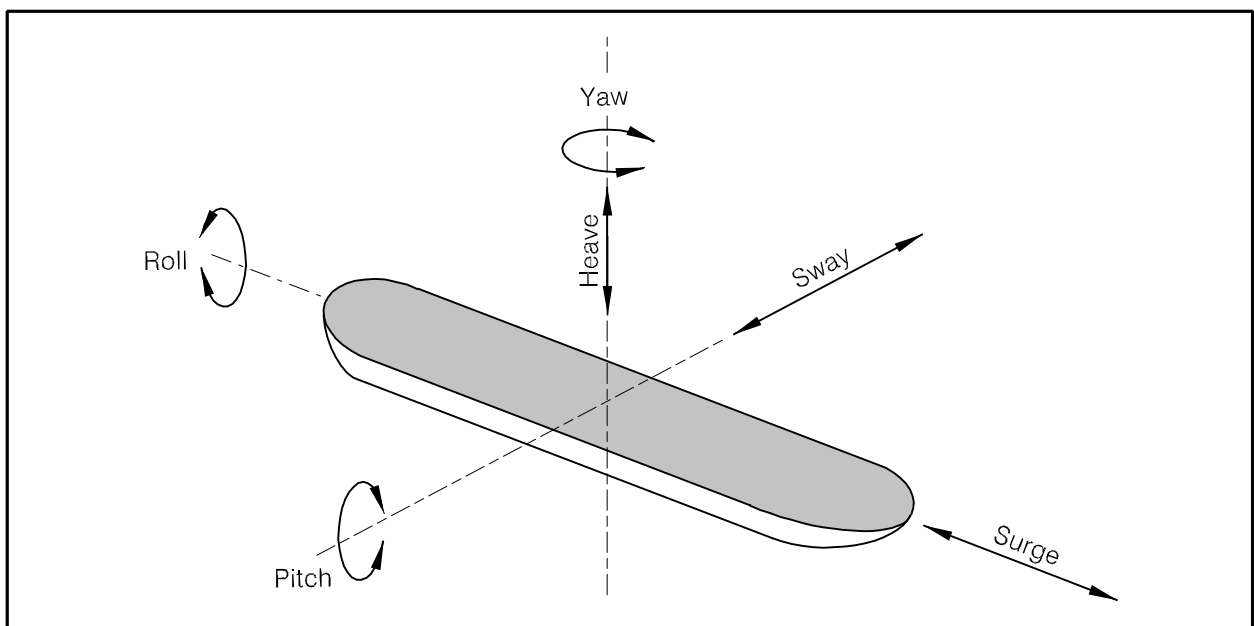

Figure 2 – Degree of Freedom of Vessel Movement

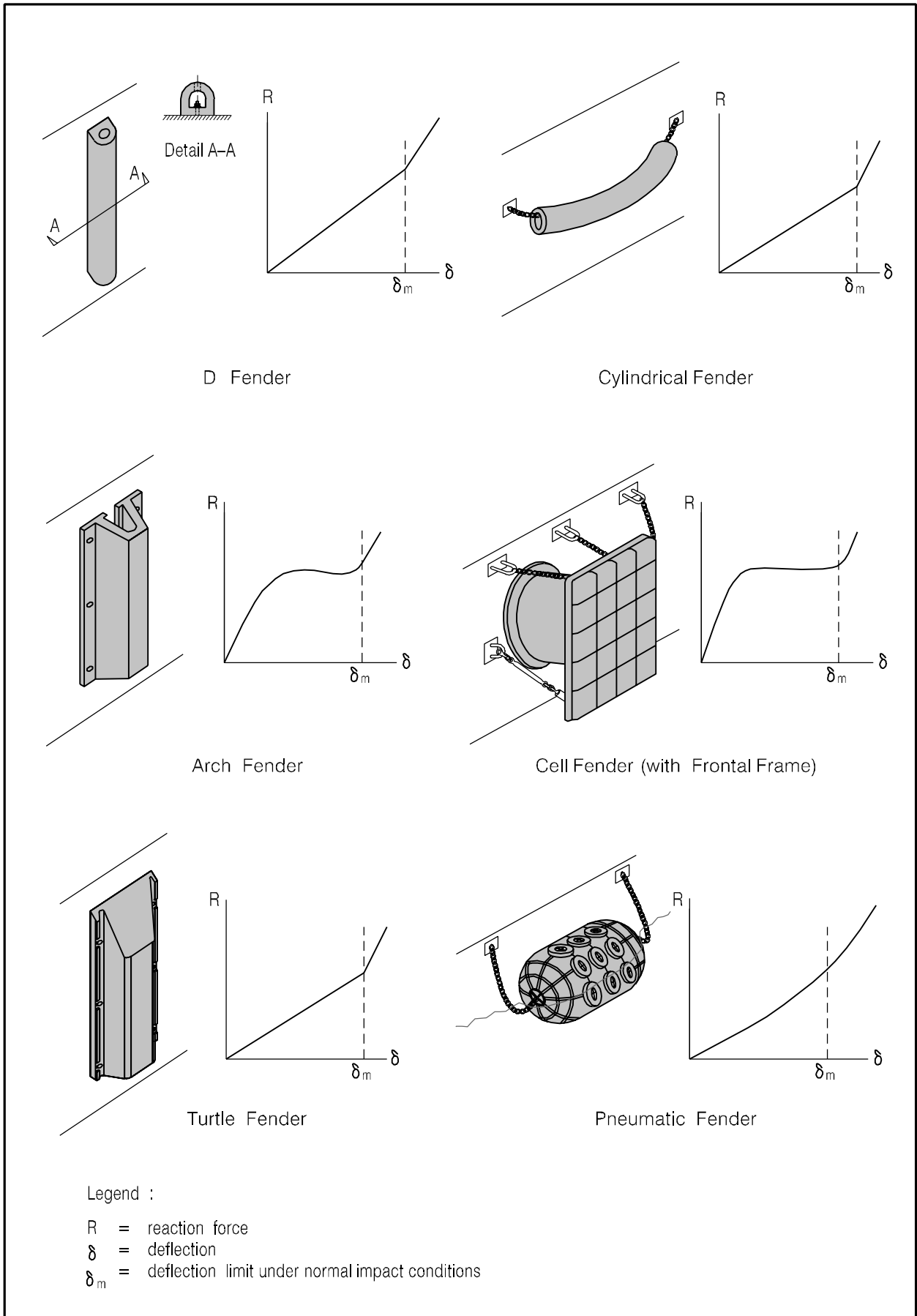

Figure 3 – Rubber Fenders

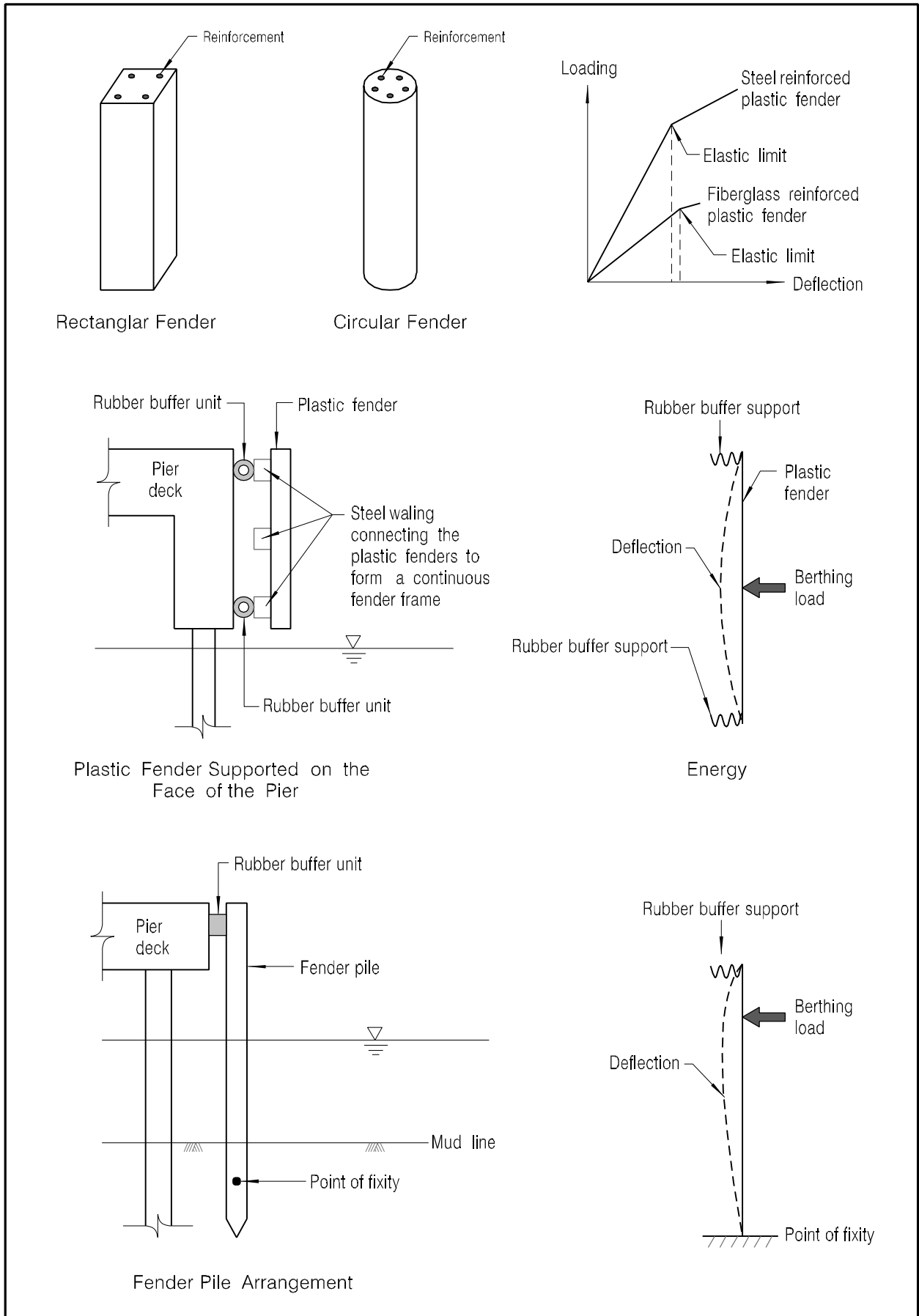

Figure 4 – Plastic Fenders

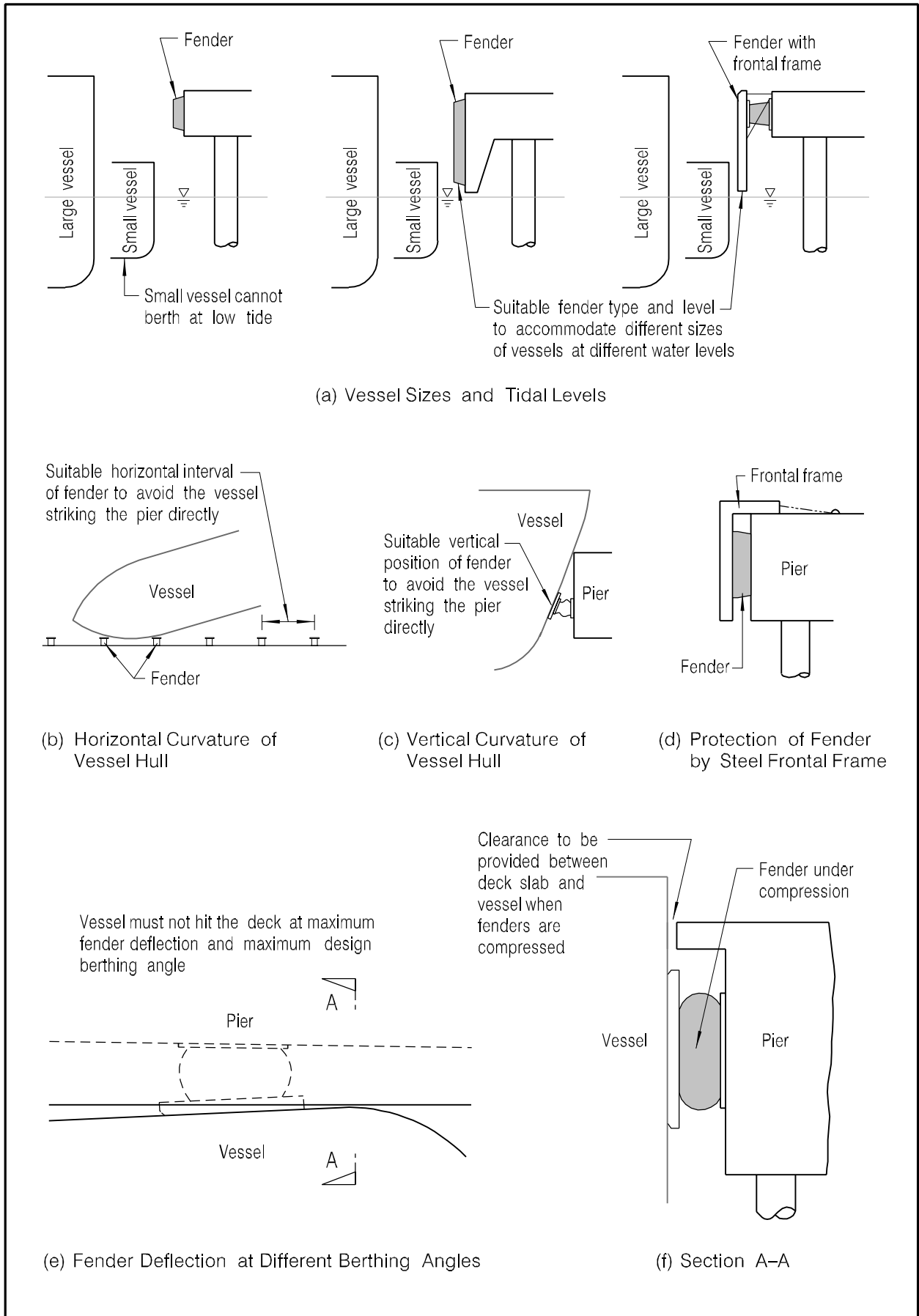
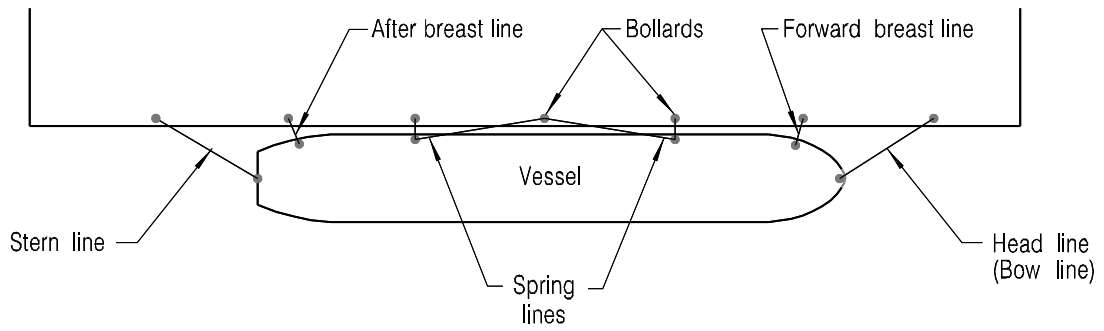
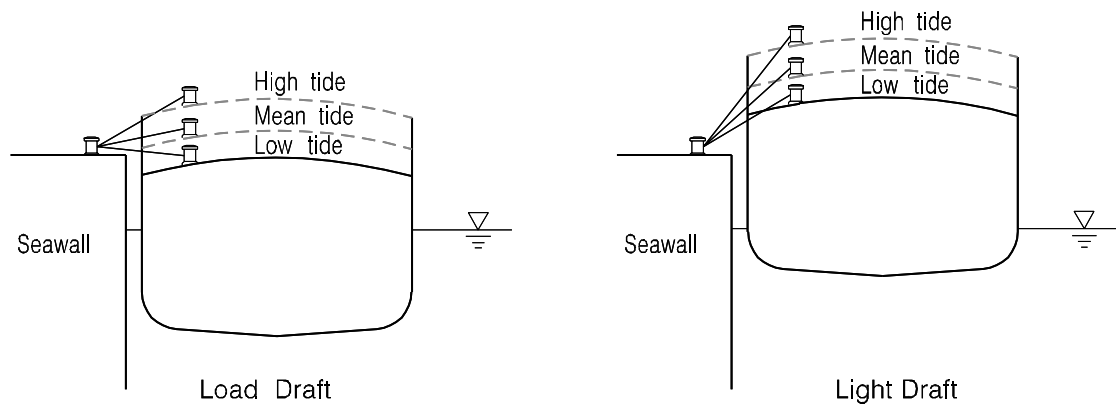

Figure 5 – Fender Arrangement



(a) General Arrangement



(b) Effect of Tidal Level and Vessel Draft

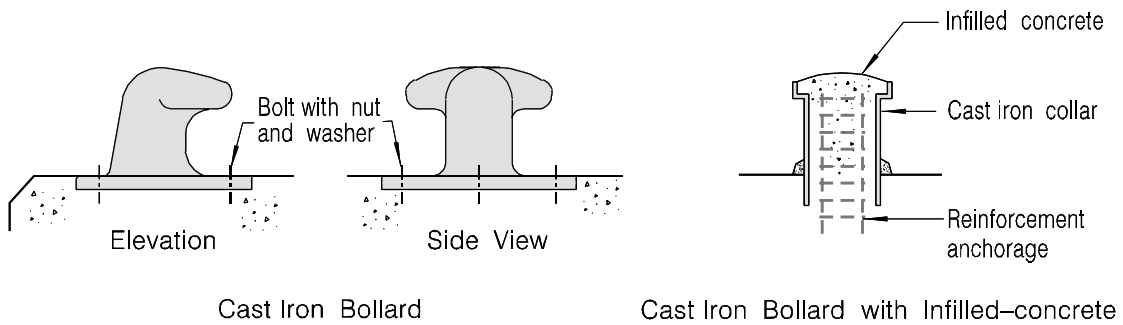

(c) Bollard

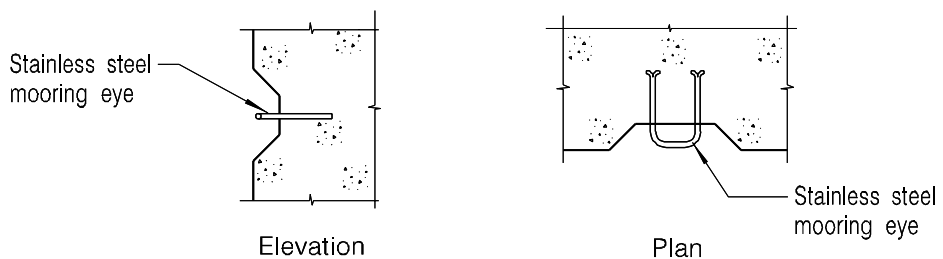

(d) Mooring Eye

Note: Actual mooring arrangement depends on mooring layout of the pier and type of vessel.

Figure 6 – Mooring Arrangement

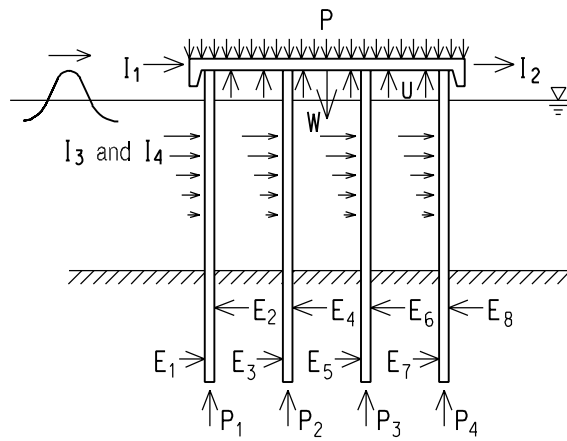

(a) Pier on Vertical Piles Only

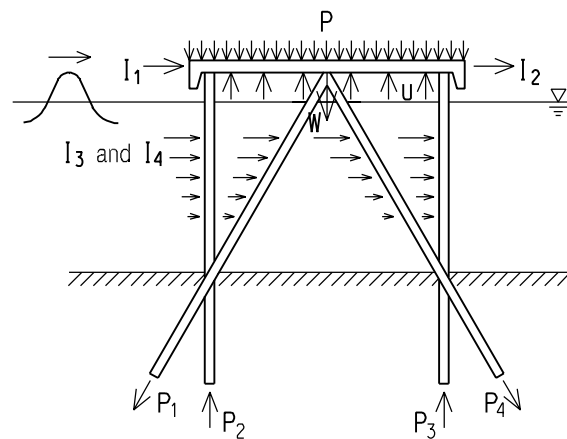

(b) Pier on Vertical and Raking Piles

Legend:

- W Dead load
- P Vertical load
- I_1, I_2 Horizontal load on deck
(e.g. wave load, wind load transferred from superstructure, berthing load, mooring load)
- I_3, I_4 Horizontal load on piles (e.g. wave load, cement load)
- E_i Soil reaction ($i=1, 2, \dots$)
- P_i Axial load on pile ($i=1, 2, \dots$)
- U Uplift (e.g. buoyancy, wave uplift)

Figure 7 – Flexible and Rigid Piled Deck Structures

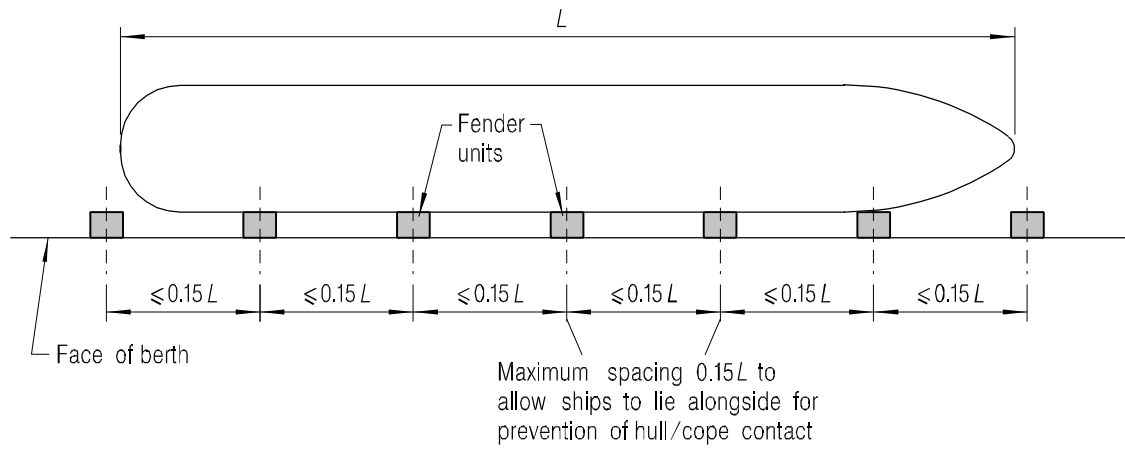

Legend :

L = Length of vessel

(a) Horizontal Spacing

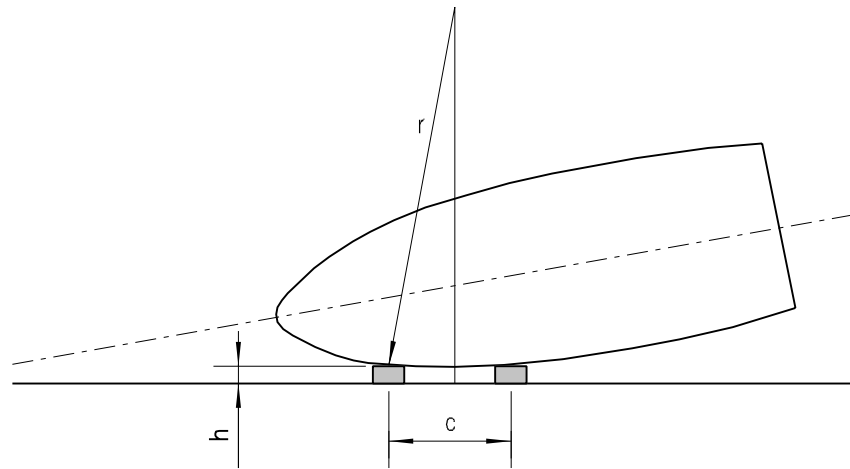

The spacing of fenders (c) to be adjusted to avoid direct contact of vessel and structure :

$$\text{maximum spacing} = 2 [r^2 - (r-h)^2]^{1/2}$$

r = bent radius of the vessel
 h = height of fenders when design berthing energy is absorbed

(b) Hull Geometry and Fender Spacing

Figure 8 – Fender Spacing

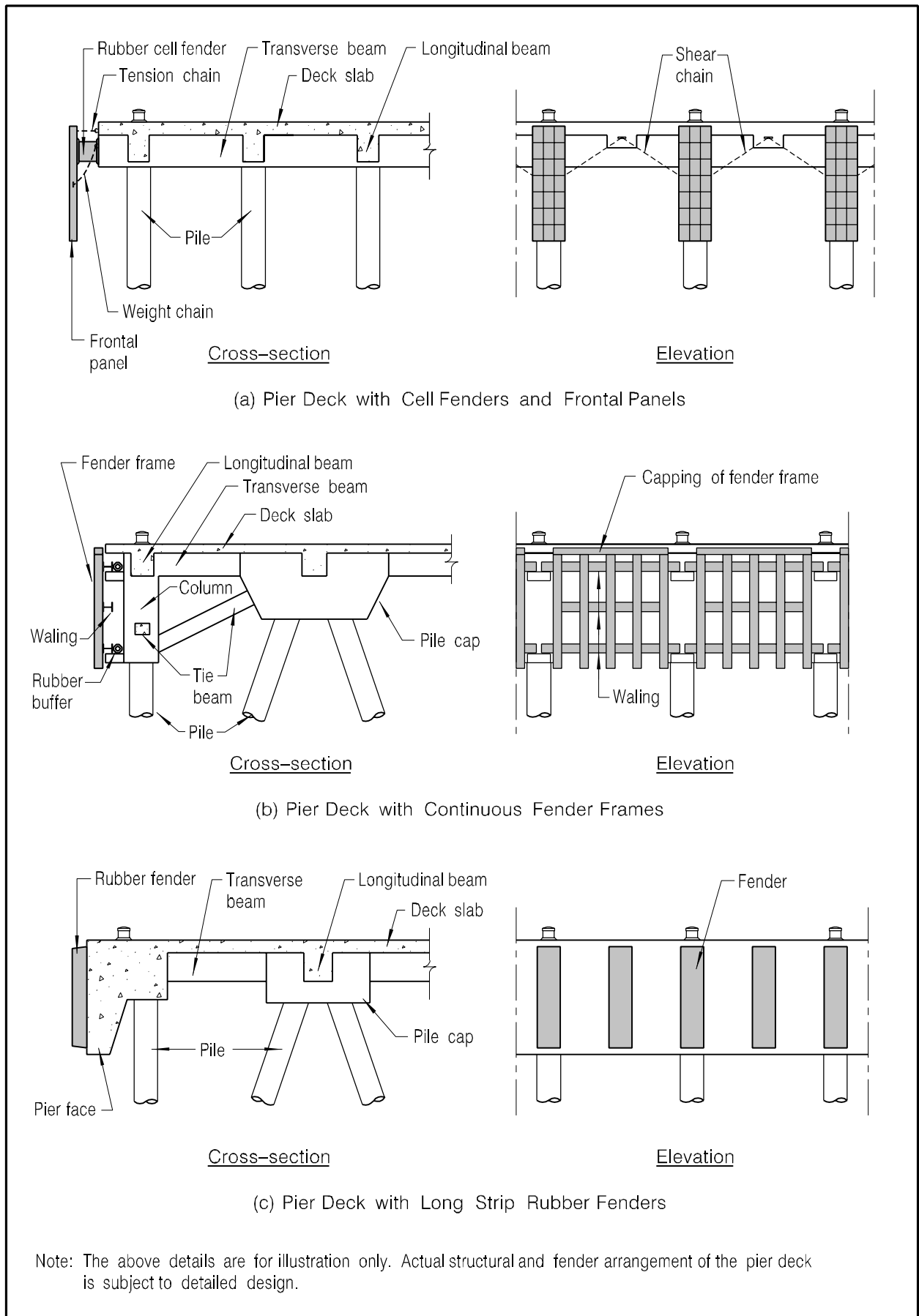

Figure 9 – Cross-section of Reinforced Concrete Piled Deck Pier

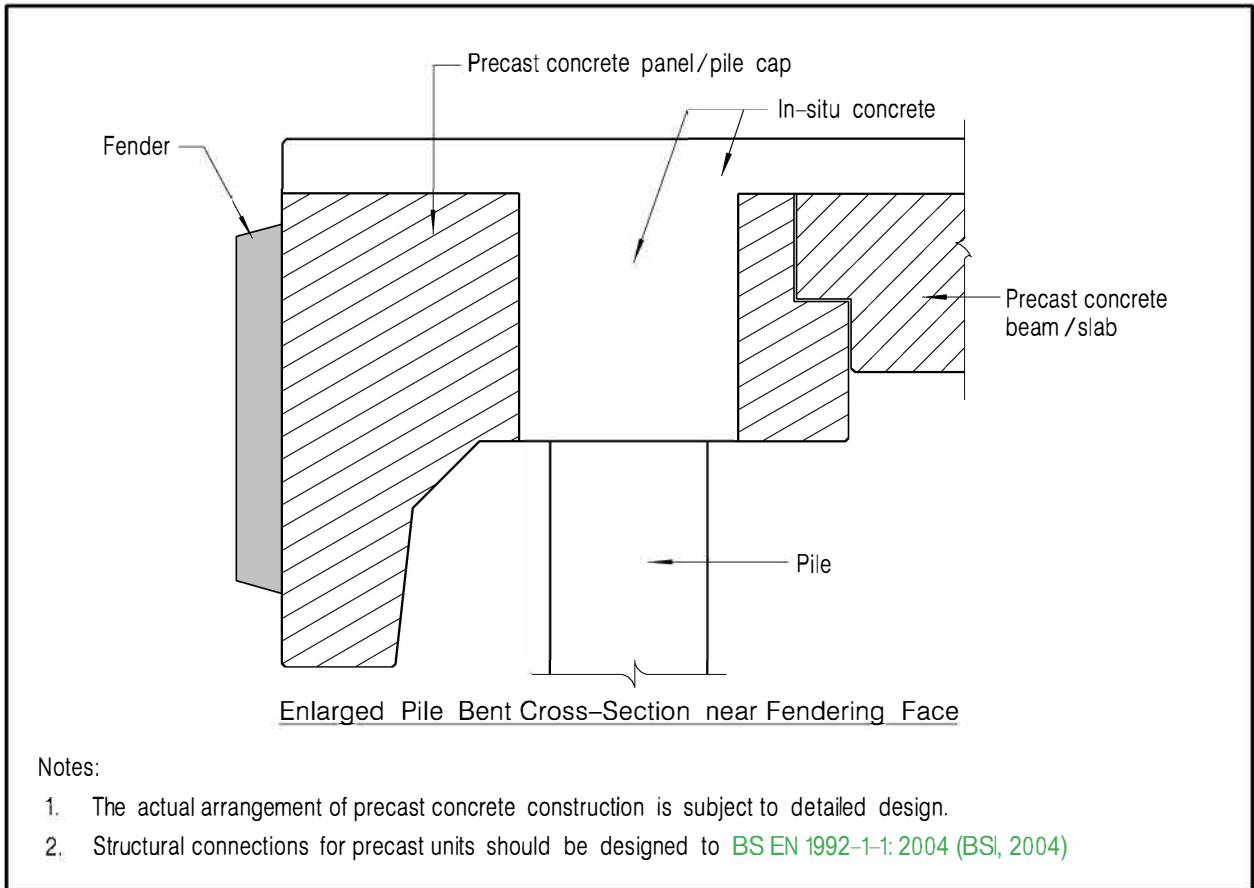

Figure 10 – Precast Concrete Construction for Piled Deck Pier

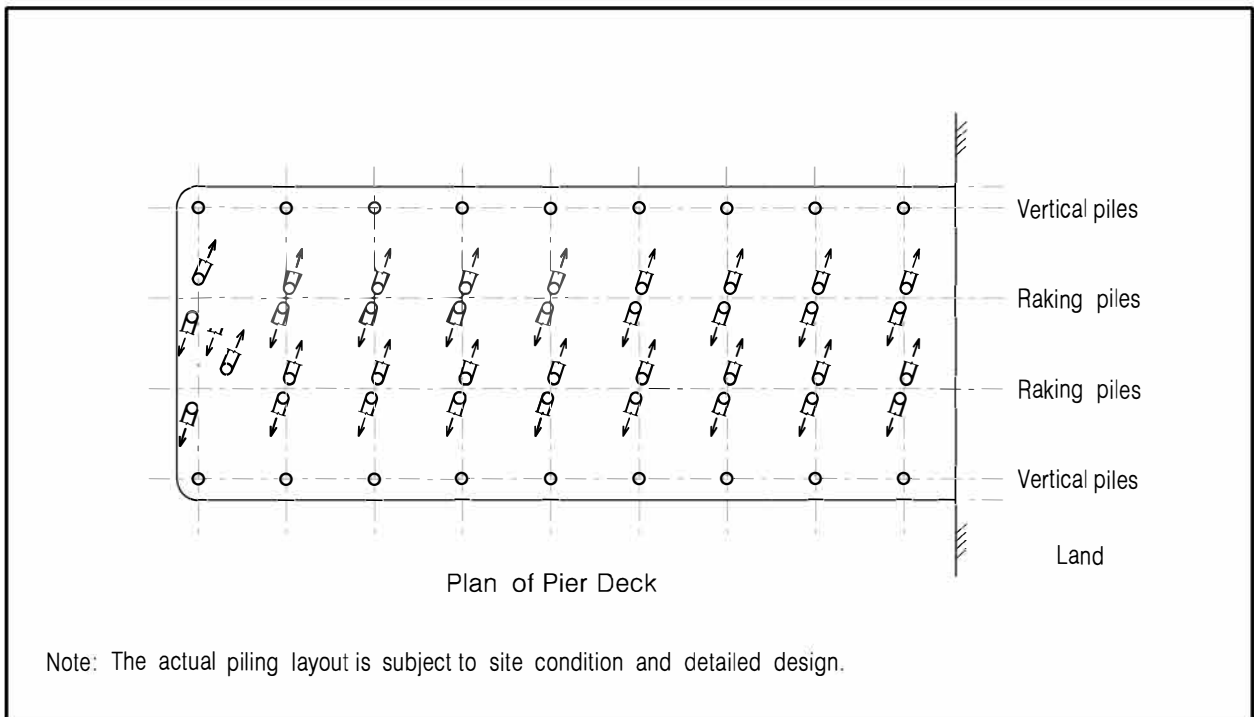

Figure 11 – Piling Layout

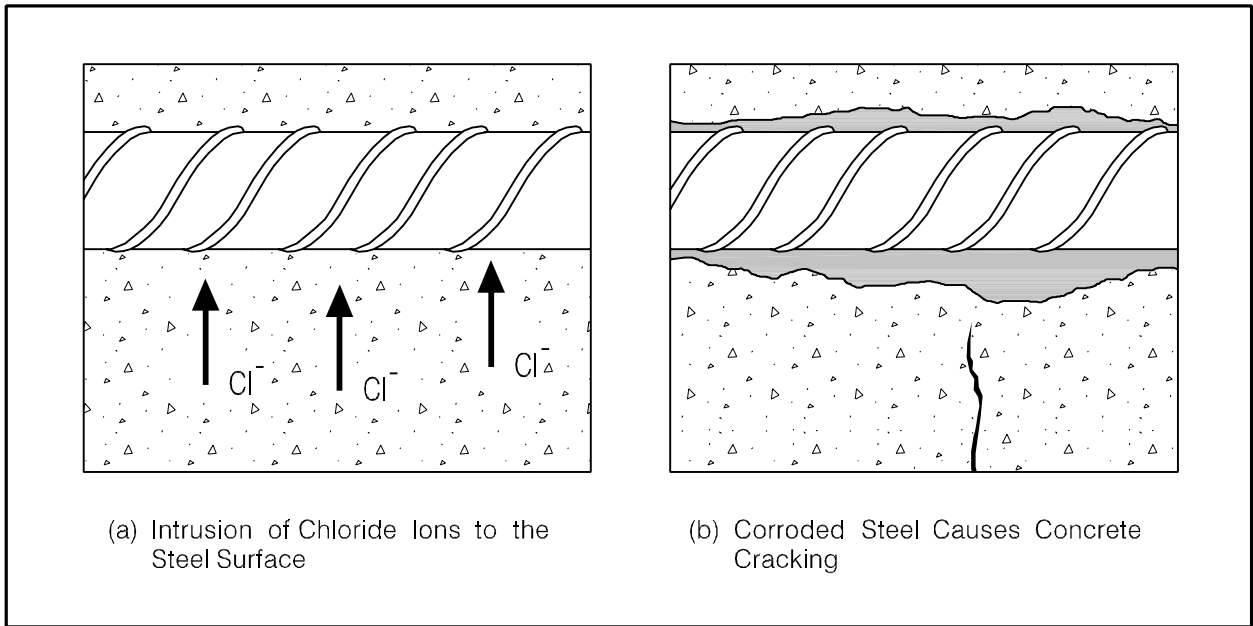

Figure 12 – Corrosion Process of Reinforcement

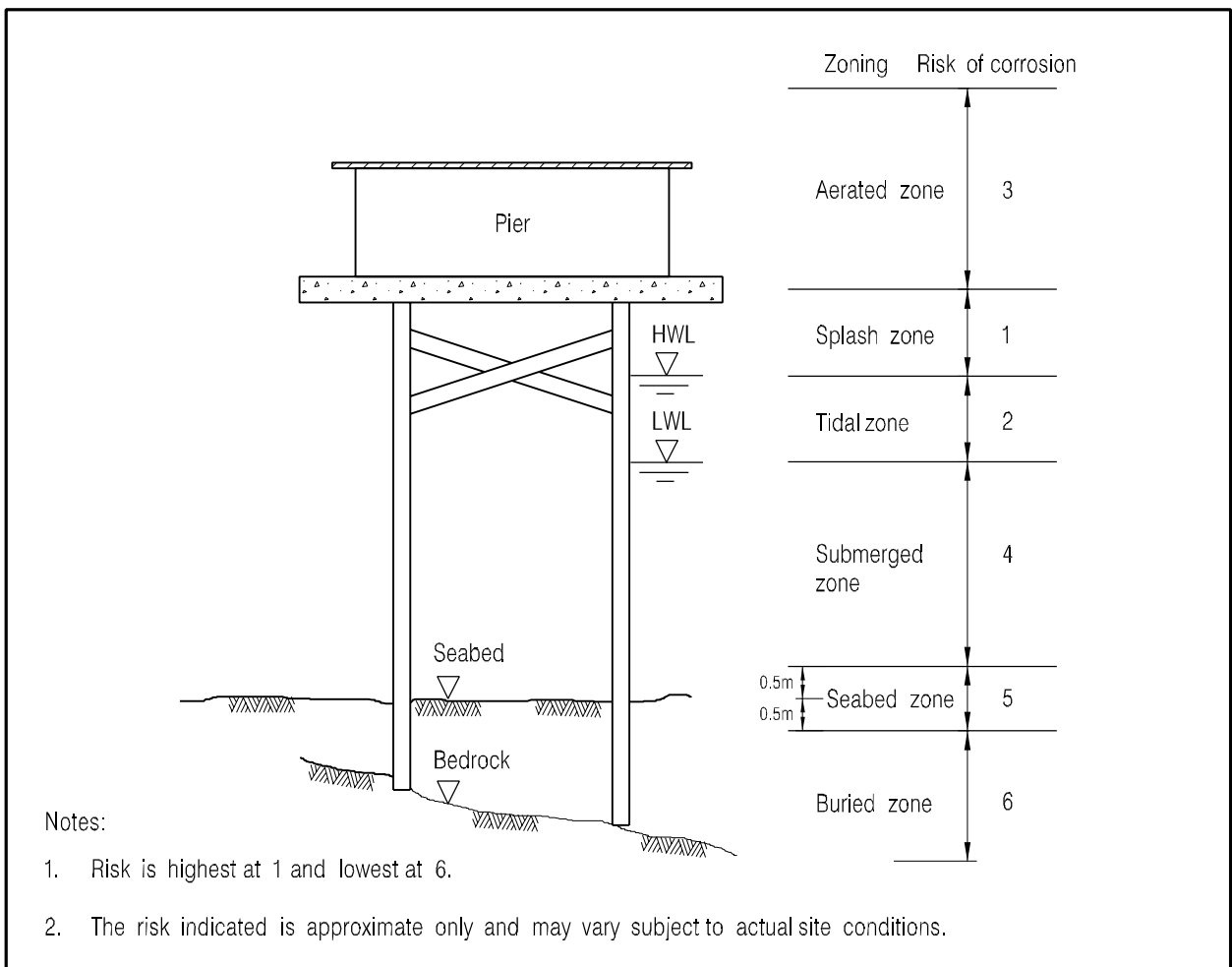

Figure 13 – Vertical Zoning of Marine Environment

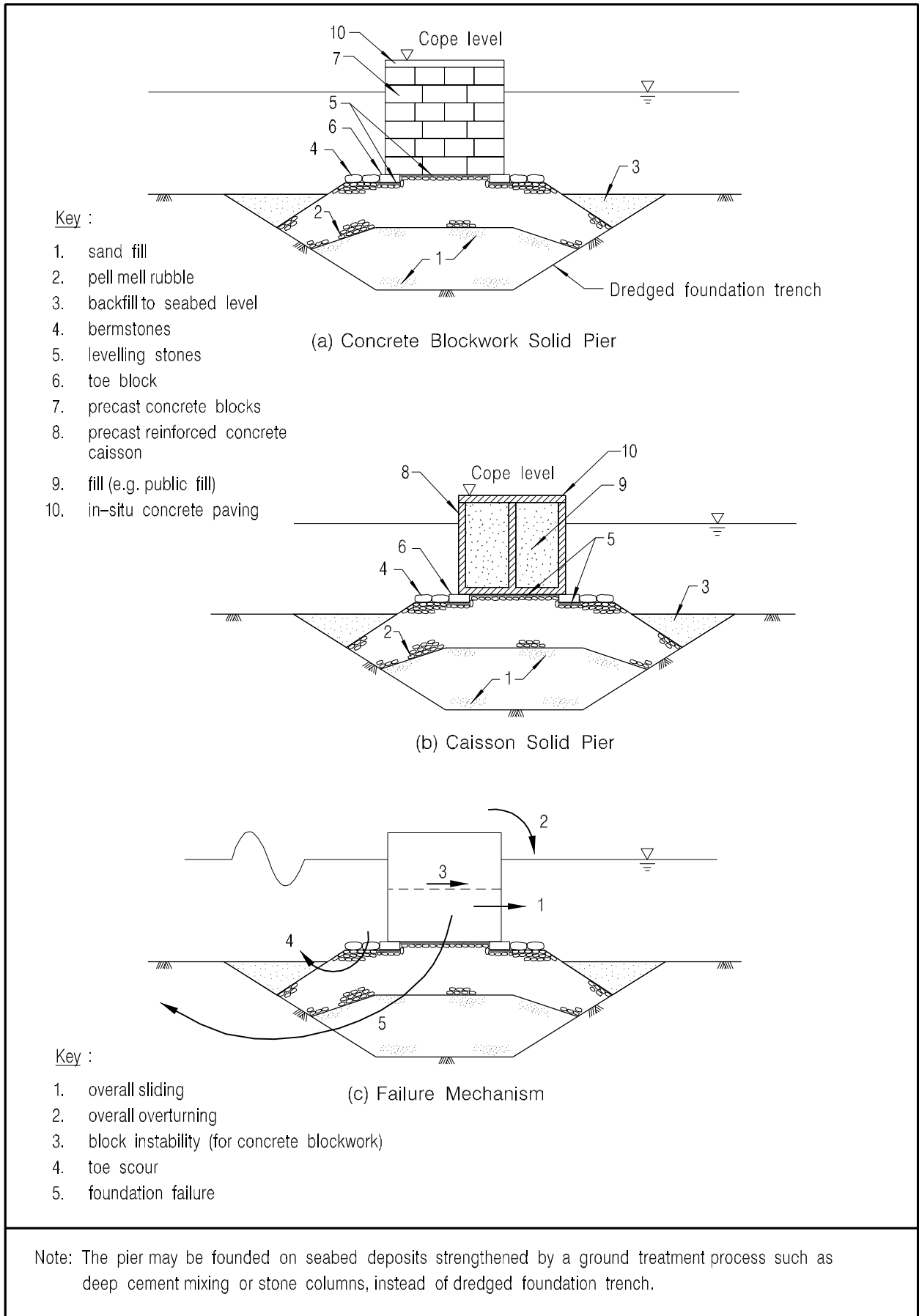

Figure 14 – Key Elements and Failure Mechanism of Solid Pier

$$W = \frac{w_r H^3}{N_s^3 (s_r - 1)^3}$$

$$B \geq 0.4d_s$$

$$B = 2H \text{ or } 4 \text{ times size of rock}$$

whichever is greater

H = Design wave height

w_r = Unit weight of rock

$$s_r = \frac{\rho_{\text{rock}}}{\rho_{\text{water}}}$$

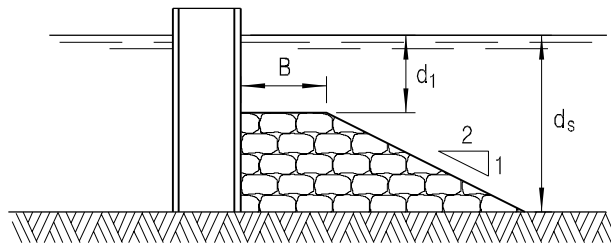

(a) Rubble Toe Protection

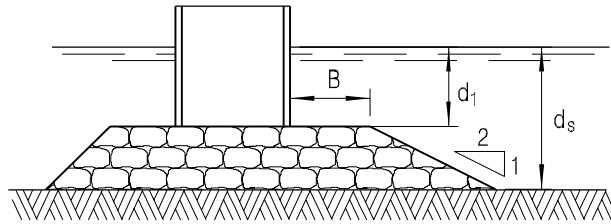

(b) Rubble Foundation

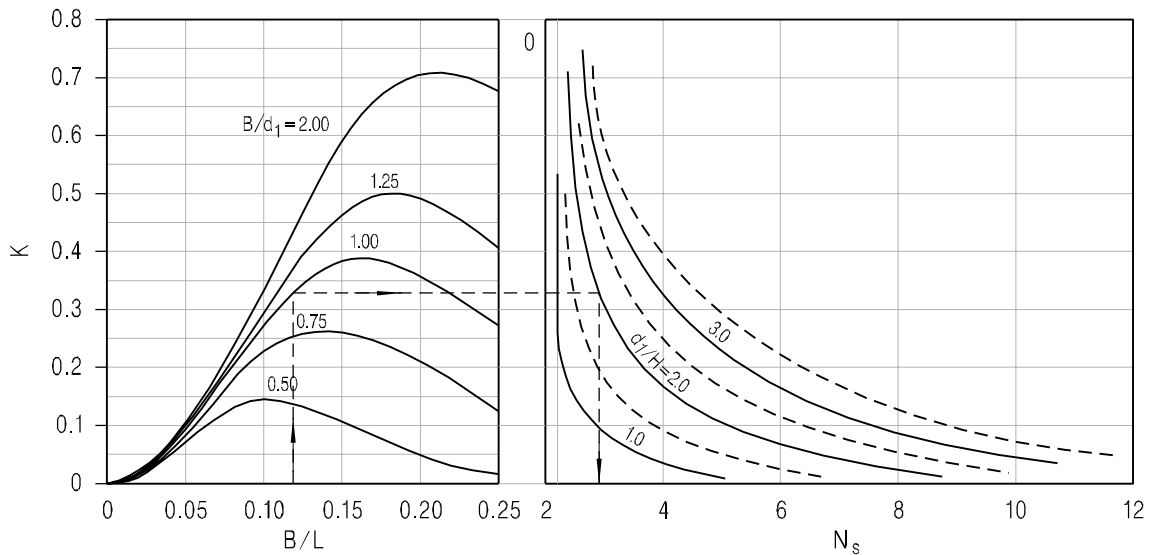

where: K = parameter representing the combined effects of the relative water depth and the relative distance from the vertical wall on the maximum horizontal velocity at the bottom.
 H = design wave height associated with depth d_s
 L = wavelength associated with the depth d₁
 d_s = depth at structure
 B = toe apron width

Note:

1. For critical structures at open exposed sites where failure would be disastrous, and in the absence of reliable wave records, the design wave height should be the H₁₀₀ during an extreme event at the structure corrected for refraction and shoaling. If breaking might prevent the H₁₀₀ wave from reaching the structure, the maximum wave that could reach the structure should be taken for the design value of H. For less critical structures, design wave height could be taken between H₁₀ and H₁₀₀.

Source: CETN (1988) and Tanimoto et al (1982)

Figure 15 – Toe Protection

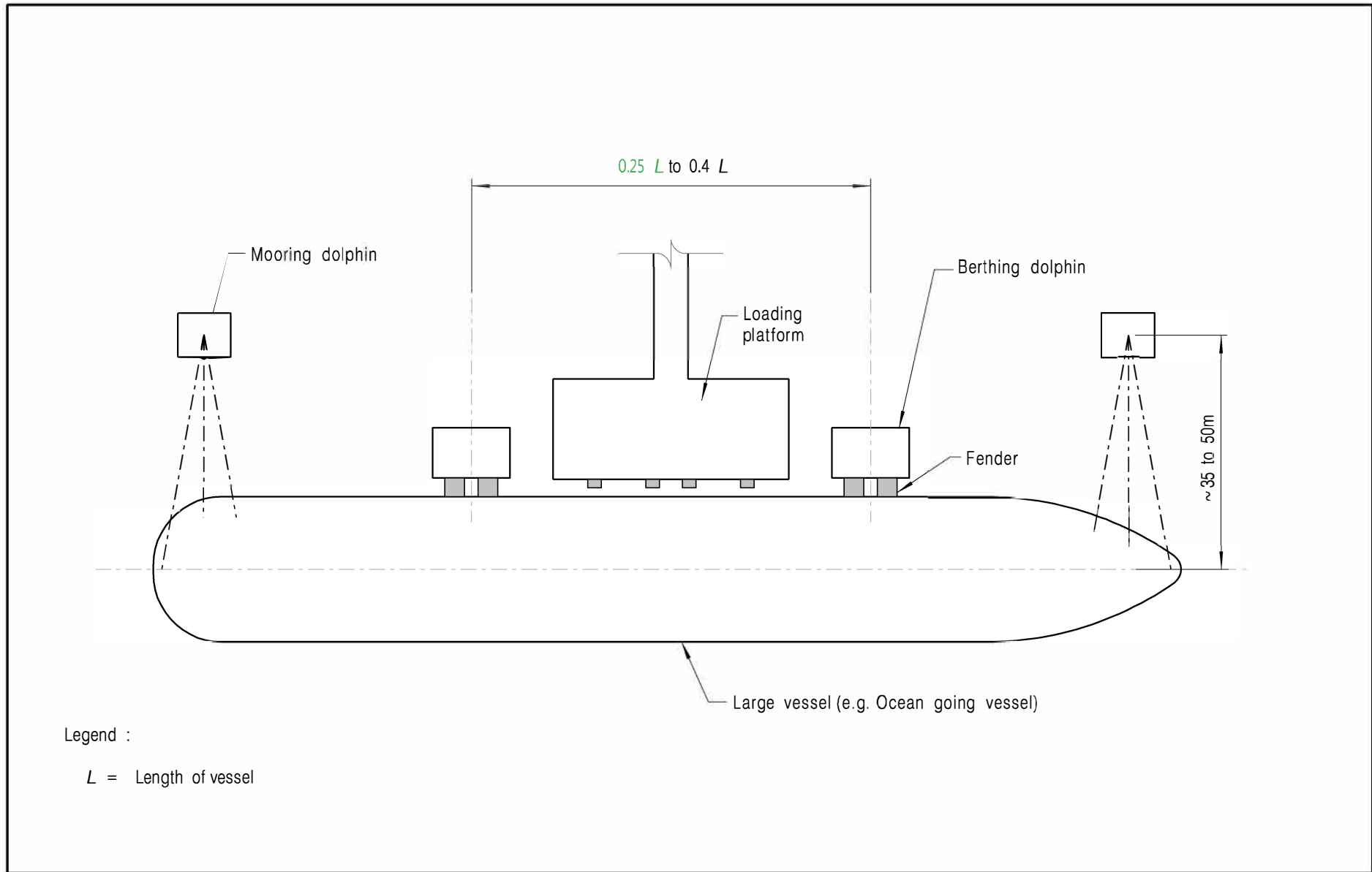

Figure 16 – Layout of Dolphin

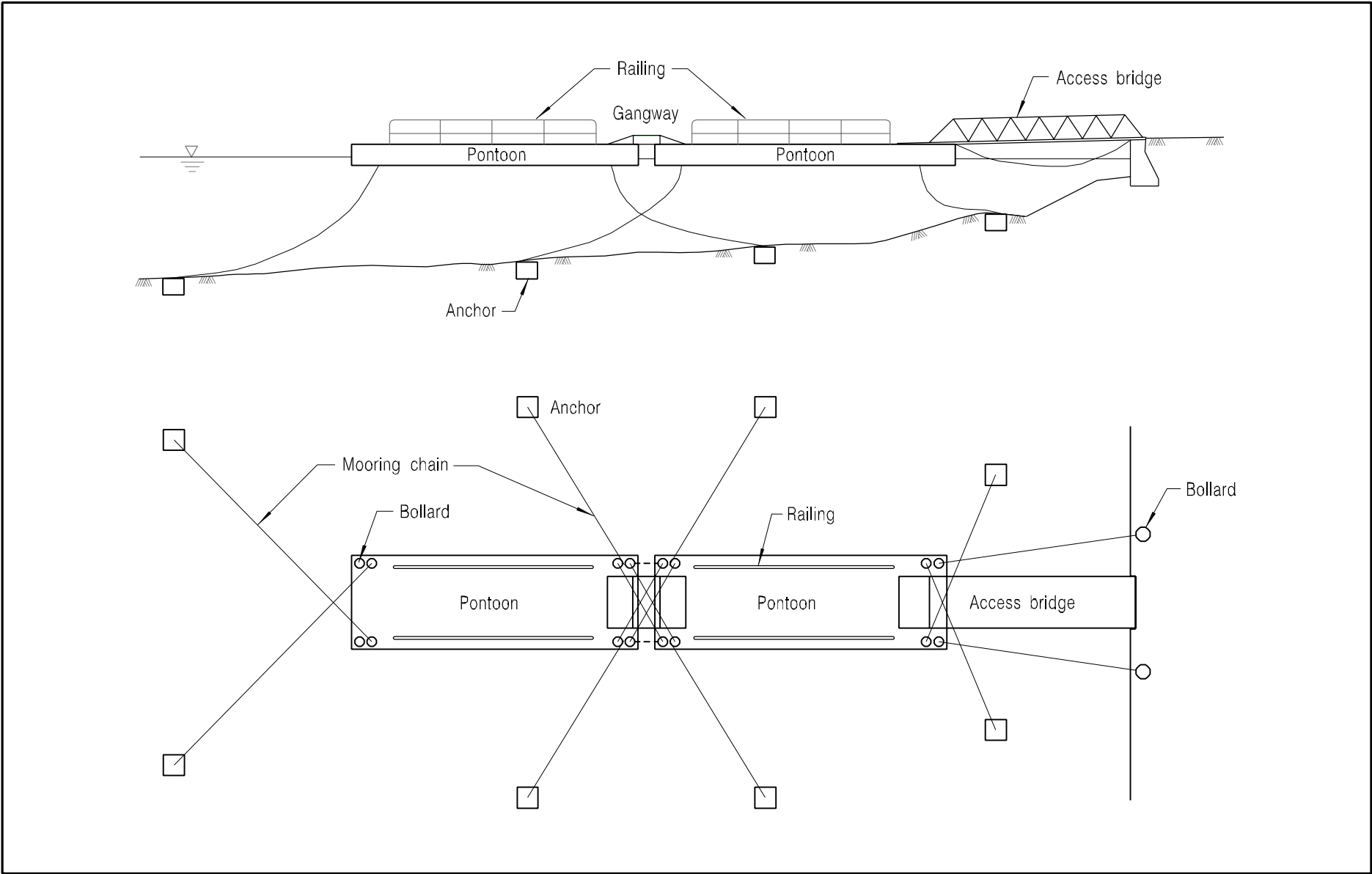

Figure 17 – Floating Pier with Anchor Chain

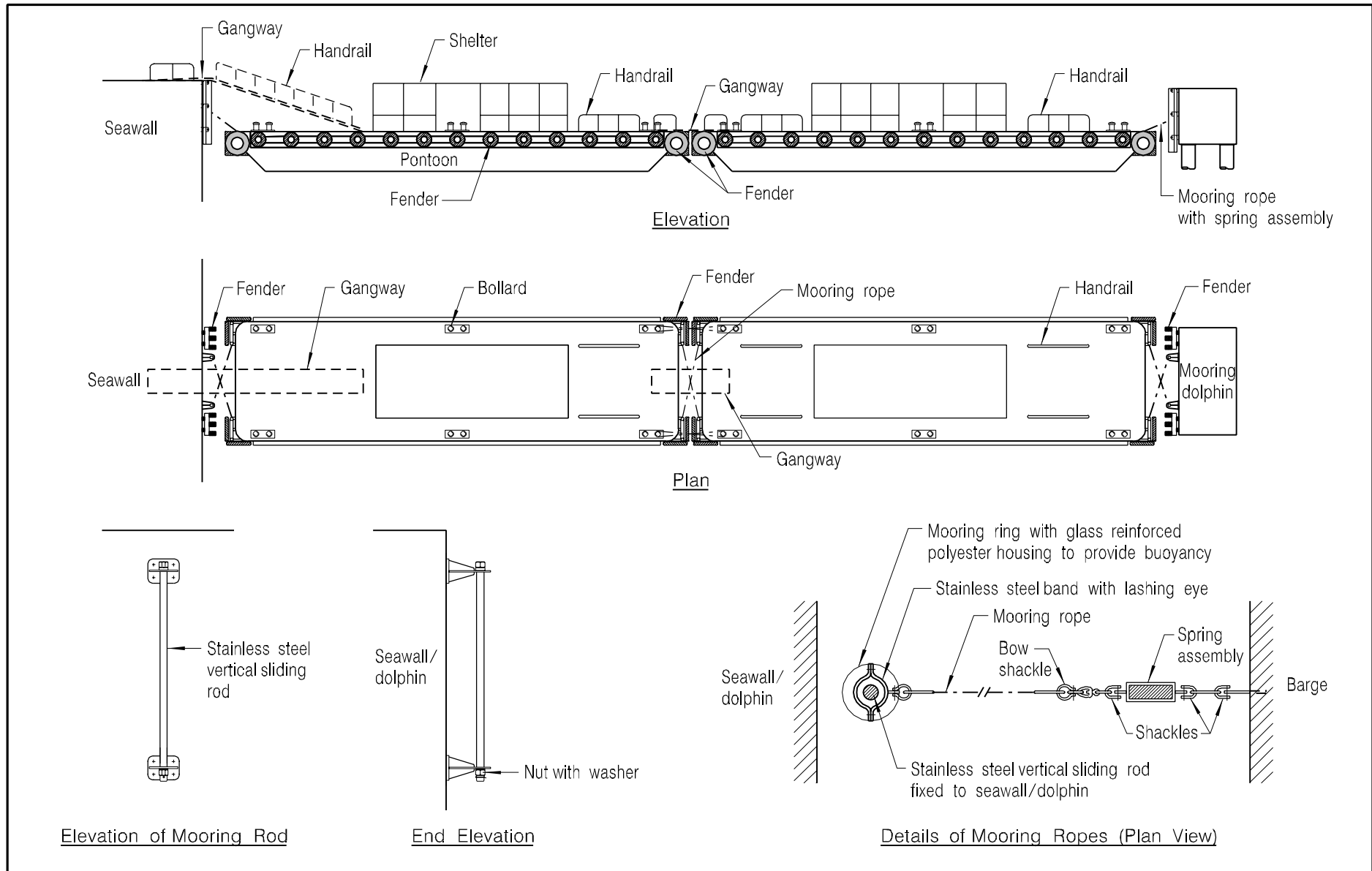

Figure 18 – Floating Jetty

PLATES

LIST OF PLATES

Plate No.		Page No.
1	Ferry Pier supported on Piles	101
2	Solid Pier made of Precast Concrete Blocks and Rubble Mound Catwalk	101
3	Cell Fenders with Frontal Panel	102
4	Pneumatic Fenders and Arch Fenders	102
5	Cylindrical Fenders	103
6	Plastic Fenders	103
7	Precast Concrete Pile Cap	104
8	Precast Concrete Beam and Slab	104
9	Mooring Dolphin	105
10	Floating Pier moored between a Seawall and a Dolphin	105
11	Pak Sha Wan Public Pier	106
12	Hei Ling Chau Pier	106
13	Wu Kai Sha Public Pier	107
14	Cheung Chau Public Pier	107
15	Kat O Chau Public Pier	108
16	Ferry Pier with Glass Wall in Central District	108



Plate 1 – Ferry Pier supported on Piles



Plate 2 – Solid Pier made of Precast Concrete Blocks and Rubble Mound Catwalk



Plate 3 – Cell Fenders with Front Panel



Plate 4 – Pneumatic Fenders and Arch Fenders



Plate 5 – Cylindrical Fenders



Plate 6 – Plastic Fenders



Plate 7 – Precast Concrete Pile Cap



Plate 8 – Precast Concrete Beam and Slab



Plate 9 – Mooring Dolphin



Plate 10 – Floating pier moored between a Seawall and a Dolphin



Plate 11 – Pak Sha Wan Public Pier



Plate 12 – Hei Ling Chau Pier



Plate 13 – Wu Kai Sha Public Pier



Plate 14 – Cheung Chau Public Pier



Plate 15 – Kat O Chau Public Pier



Plate 16 – Ferry Pier with Glass Wall in Central District

APPENDIX A
DESIGN OF FENDERS

APPENDIX A DESIGN OF FENDERS

A.1 Example 1

Given

Details of design vessels for a proposed solid pier are given as follows :

	Type 1 Vessel	Type 2 Vessel
Length	8.0 m	35.0 m
Beam	5.0 m	20.0 m
Depth	1.2 m	2.5 m
Draft	0.7 m	1.5 m
Displacement	25 tonnes	400 tonnes
Bent radius of bow side of vessel	10.0 m	25.0 m

Determine the layout and the size of rubber fenders.

Solution

(a) Length of fenders

Low water level = +0.2 mPD

High water level = +3.0 mPD

Freeboard for Type 1 Vessel = $1.2 - 0.7 = 0.5$ m

Freeboard for Type 2 Vessel = $2.5 - 1.5 = 1.0$ m

Length of fenders = 3.5 m, extending from +0.15 mPD to +3.65 mPD to allow berthing under low and high water levels.

The relationship between fenders and vessels at different water levels is shown as follows :

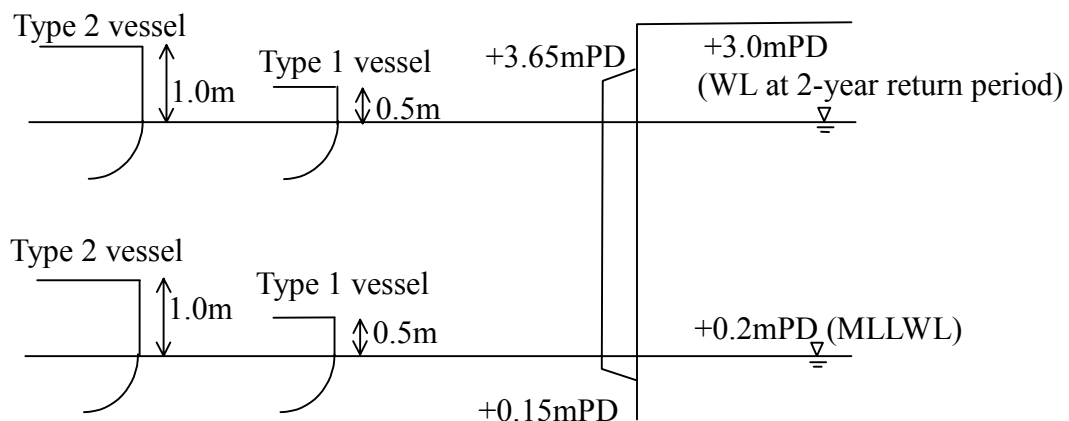

(b) Spacing of fenders (See Figure 8)

The length of the small vessel (Type 1 Vessel) using the pier = 8.0 m

Maximum fender spacing = $0.15 \times 8.0 \text{ m} = 1.2 \text{ m}$

Smallest bent radius of bow side of vessel = 10.0 m

Height of fenders = 0.25 m

Maximum fender spacing = $2 \times [10^2 - (10 - 0.25)^2]^{1/2} = 4.4 \text{ m}$

Therefore, use fender spacing of 1.2 m.

(c) Size of fenders

Based on the dimensions of the vessels :

- Distance of the point of contact of Type 1 Vessel from its centre of mass = 3.0m
- Distance of the point of contact of Type 2 Vessel from its centre of mass = 12.0m

Assume that the angle between the line joining the point of contact to the centre of mass and the velocity vector of the vessel = 45°

Calculation of berthing energy (see Section 5.12 of Part 1 of the Manual) :

	Type 1 Vessel	Type 2 Vessel
V_b	0.4 m/s	0.3 m/s
$C_m = 1+2(D_v/B_v)$	$1+2(0.7/5.0) = 1.28$	$1+2(1.5/20.0) = 1.15$
$C_e = (K_v^2 + R_v^2 \cos^2 v) / (K_v^2 + R_v^2)$ Where $K_v = (0.19C_b + 0.11) L_v$	$K_v = [0.19 \times 25 \times 10^3 / (8 \times 5 \times 0.7 \times 1025) + 0.11] \times 8 = 2.2$ $C_e = (2.2^2 + 3.0^2 \cos^2 45) / (2.2^2 + 3.0^2) = 0.67$	$K_v = [0.19 \times 400 \times 10^3 / (35 \times 20 \times 1.5 \times 1025) + 0.11] \times 35 = 6.32$ $C_e = (6.32^2 + 12.0^2 \cos^2 45) / (6.32^2 + 12.0^2) = 0.61$
C_s	1.0	1.0
C_c (for solid pier)	0.9	0.9
Berthing energy	$0.5(1.28 \times 25 \times 0.4^2 \times 0.67 \times 1.0 \times 0.9) = 1.5 \text{ kNm}$	$0.5(1.15 \times 400 \times 0.3^2 \times 0.61 \times 1.0 \times 0.9) = 11.4 \text{ kNm}$

The total energy to be absorbed for accidental loading should be at least 50% greater than that for normal loading.

Therefore, select a rubber fender from the supplier's catalogue with design energy absorption

capacity greater than $11.4 \times 1.5 = 17.1 \text{ kNm}$

Since the pier has many fenders installed at a close spacing, the effect of angular compression on the fenders is neglected.

From the performance curve of the fender, the berthing reaction = 325 kN

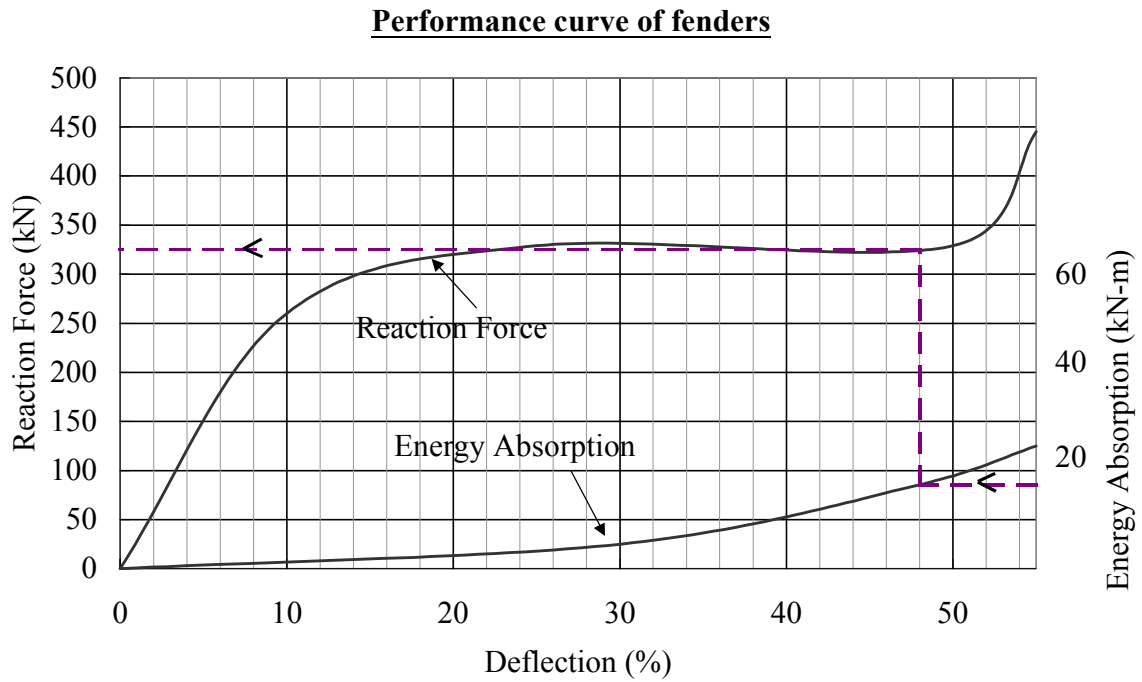

A.2 Example 2

Given

The existing timber fenders of a piled deck ferry pier are to be replaced by plastic fenders. Determine the size of the plastic fenders, waling and rubber buffers. The design data are as follows:

Design vessel

Displacement = 940 tonnes

Length = 65.0 m

Beam = 12.0 m

Depth = 4.3 m

Draft = 2.0 m

Existing fender frame

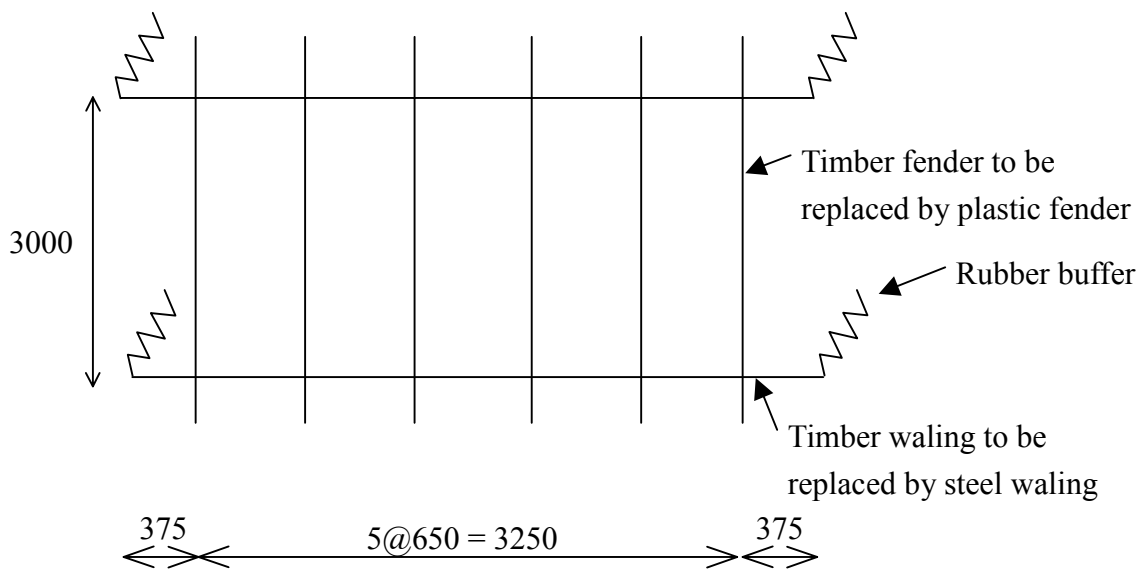

Dimensions in mm

Solution

(1) Try the following dimensions for the components of the fender frame

Plastic fender

Size = 300 mm x 300 mm

Modulus of elasticity, E = 32 Mpa

Moment of inertia, I = 0.0098 m⁴

Bending stress, σ = 7 Mpa

Allowable moment = $\sigma I / y = 7 \times 10^6 \times 0.0098 / (0.3/2) = 457.3 \text{ kNm}$

Rubber buffer

Cylindrical fender with outside diameter = 500 mm

Steel waling

Section = 356 x 406 x 340 kg/m Universal Column (Grade 43)

Modulus of elasticity, E = 200 MPa

Design stress = 265 Mpa

Plastic Modulus, S = 6.03 x 10⁶ mm³

Moment capacity = 265 x 6.03 = 1598 kNm

(2) Calculation of berthing energy

Assume the distance of the point of contact of the vessel from its centre of mass = 20m

Angle between the line joining the point of contact to the centre of mass and the velocity vector,

$$\gamma = 45^\circ$$

$$V_b = 0.3 \text{ m/s}$$

$$C_m = 1 + 2(2.0/12) = 1.33$$

$$K_v = [0.19 \times 940 \times 10^3 / (65 \times 12 \times 2.0 \times 1025) + 0.11] \times 65 = 14.41$$

$$C_e = (14.41^2 + 20^2 \cos^2 45) / (14.41^2 + 20^2) = 0.67$$

$$C_s = 1.0$$

$$C_c = 1.0 \text{ for piled deck pier}$$

$$\text{Berthing energy} = 0.5 \times (1.33 \times 940 \times 0.3^2 \times 0.67 \times 1.0 \times 1.0) = 37.7 \text{ kNm}$$

(3) Capacity of the fender frame

The capacity of the fender system is checked for the following load cases:

Load case 1: Berthing load at close proximity to the buffer

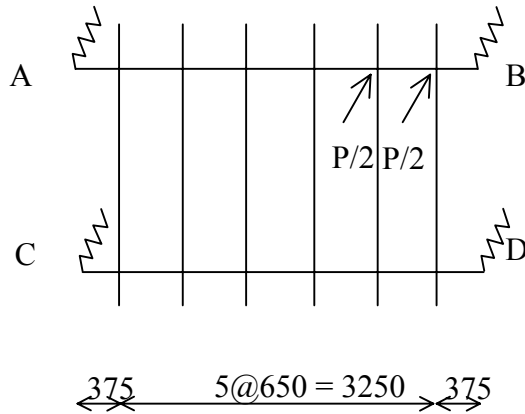

Let the berthing load be P.

Assume that the design vessel collides with two fenders at one time and the berthing load P is equally shared between the two fenders. Since the berthing load P is very close to the buffer, it is assumed that all the berthing energy is absorbed by the buffer at B only. The total energy to be absorbed for accidental loading should be at least 50% greater than that for normal loading.

Berthing energy to be absorbed = $37.7 \times 1.5 = 56.6 \text{ kNm}$

Performance curve of buffers

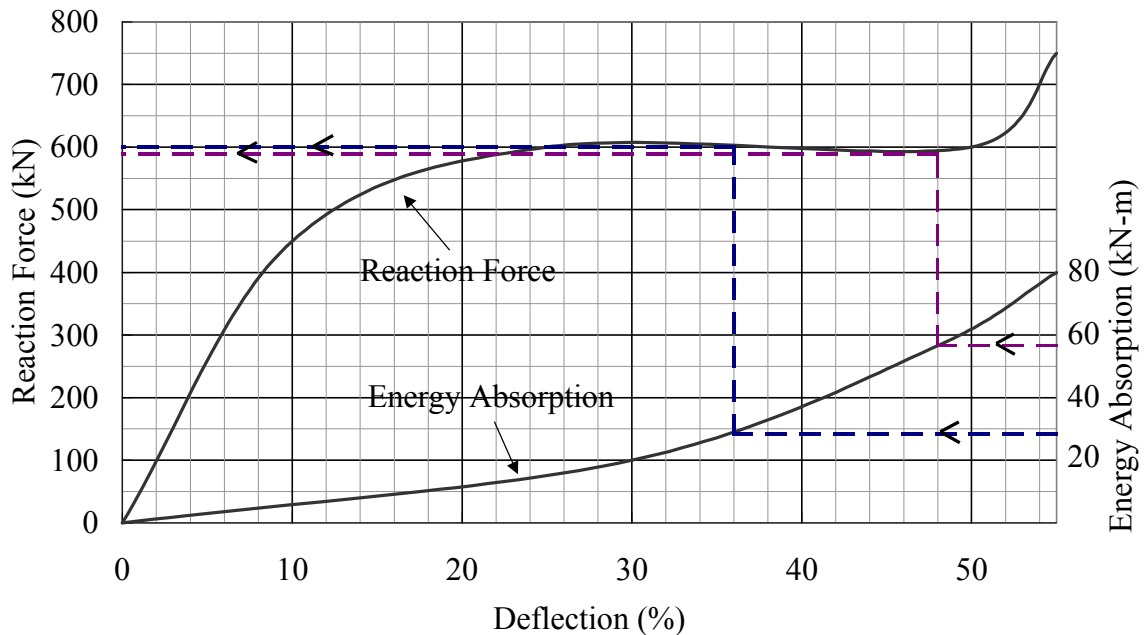

From the performance curve of the buffer,

Reaction force = 590 kN

Deflection = $48\% \times 500 = 240 \text{ mm} < 300 \text{ mm}$

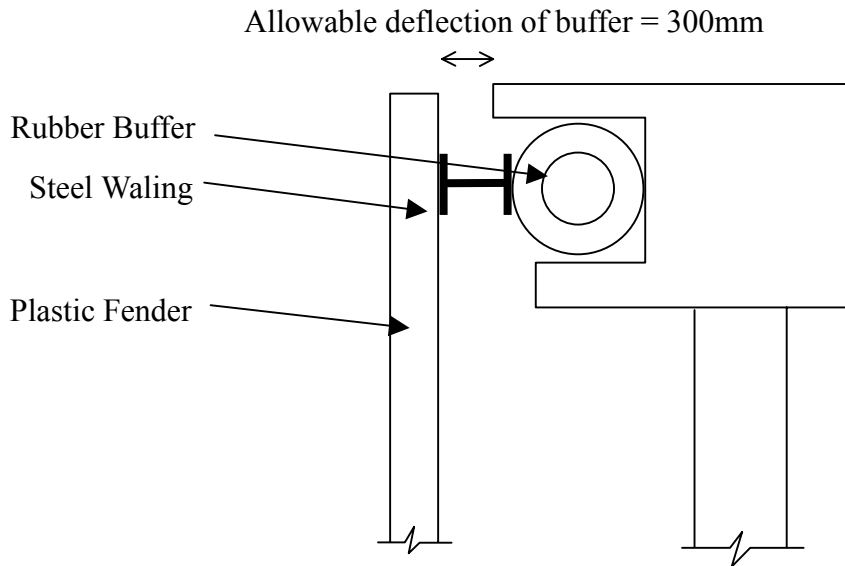

Load case 2: Berthing load at mid-span of steel waling

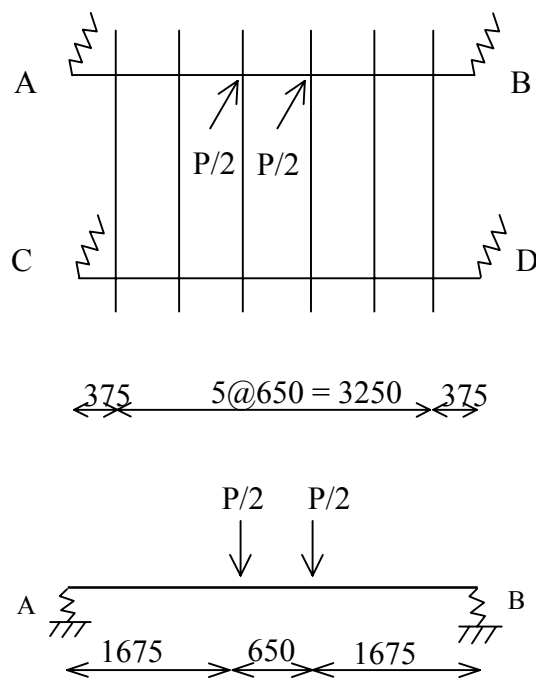

Assume that the total berthing energy is to be equally shared between two buffers (A and B).

The total energy to be absorbed for accident loading should be at least 50% greater than that for normal loading.

Therefore, berthing energy to be absorbed by one buffer = $37.7 \times 1.5 / 2 = 28.3 \text{ kNm}$

From the performance curve of the buffer, the reaction force at B = 600 kN

By symmetry, the reaction force at A = 600 kN and $P/2 = 600$ kN

Checking moment capacity of steel waling :

Maximum Moment in steel waling = $600 \times 2 - 600 \times 0.375 = 975$ kNm

Taking a load factor of 1.5 according to (BSI,2002)

Factored moment = $1.5 \times 975 = 1462.5$ kNm (<1598 kNm, OK)

Checking deflection of steel waling

Allowable deflection = $L/360 = 4000/360 = 11.1$ mm

Actual deflection of steel waling at mid-span = 6.1 mm (<11.1 mm, OK)

Note : In principle, when the load is applied at the steel waling, there is some energy absorbed by the steel waling due to bending. When the load is at mid-span, this energy is approximately equal to 3.7 kNm ($\frac{1}{2} \times 0.0061 \times 600 + \frac{1}{2} \times 0.0061 \times 600$). It is negligible in comparison to the total berthing energy of 56.5 kNm.

Load case 3: Berthing load at mid-span of plastic fenders

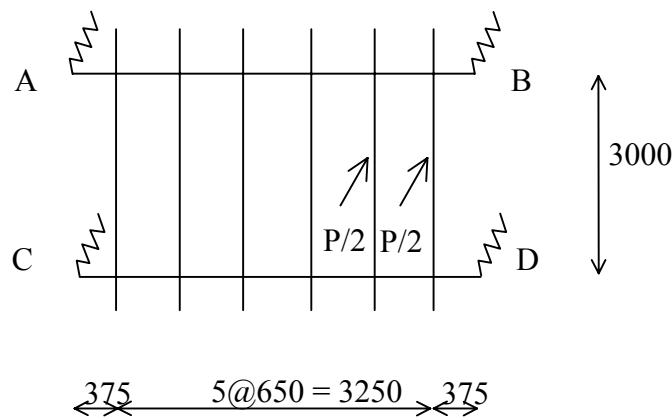

Similarly to load case 2, assume that the total berthing energy is equally shared between two buffers (B and D). Therefore, the reaction force at B = 600 kN

By symmetry, the reaction force at A = 600 kN and $P/2 = 600$ kN

Deflection of a plastic fender at mid-span

$= FL^3/16EI$ (where F is the applied load at mid-span)

$= (P/2)(3)^3/(16 \times 32 \times 10^6 \times 0.0098)$

$= 3.3$ mm

Maximum moment in one plastic fender

$$= (P/2)(3)/4$$

$$= 450 \text{ kNm } (<457.3, \text{ OK})$$

Note : In principle, when the load is applied at the two plastic fenders, there is some energy absorbed by the plastic fenders due to bending. When the load is at mid-span, this energy is approximately equal 2.0 kNm ($\frac{1}{2} \times 0.0033 \times 600 + \frac{1}{2} \times 0.0033 \times 600$). This is negligible in comparison to the total berthing energy of 56.5 kNm.

GLOSSARY OF TERMS

GLOSSARY OF TERMS

Belting.	Projections consisting of one or more timber, rubber or steel rubbing strips fitted around the hull of vessels such as ferries, tugs, launches and other small crafts for the purpose of protecting the hull.
Berth.	A place where a vessel is docked or tied up.
Bulkhead.	A term applied to vertical partition wall which subdivides the interior of a vessel into compartments or rooms.
Displacement.	The total mass of the vessel and its contents.
Freeboard.	The distance from the waterline to the upper surface of the freeboard deck at side (see Figure 12 of Part 1 of the Manual).
Gangplank.	A short bridge or platform that can be placed between the side of a vessel and the shore to allow people to board or disembark.
Hull.	The structural body of a vessel, including shell plating, framing, decks and bulkheads.
Kaito.	A small passenger carrying vessel used in local village ferry services serving remote coastal settlements.
Pile bent.	The piled foundation and associated structural members including pile caps, beams and slabs of a pier for load transfer from the superstructure to the foundation.
Public piers.	Government piers for use by public vessels not exceeding 35 m in length.
Squat.	Increase of the draft aft of a vessel when underway at speed.
Trim.	The difference between the draft forward and the draft aft of a vessel.
Under-keel clearance.	The distance between the keel of a vessel and the seabed.

